



ASPECT

STRUCTURAL ENGINEERS

ASSEMBLAGES AVEC MATÉRIAUX MIXTES

SHAWN KENNEDY
ASSOCIATE
MASc., P.Eng., Ing., PE
shawn@aspectengineers.com

BUREAUX & LOCALISATION

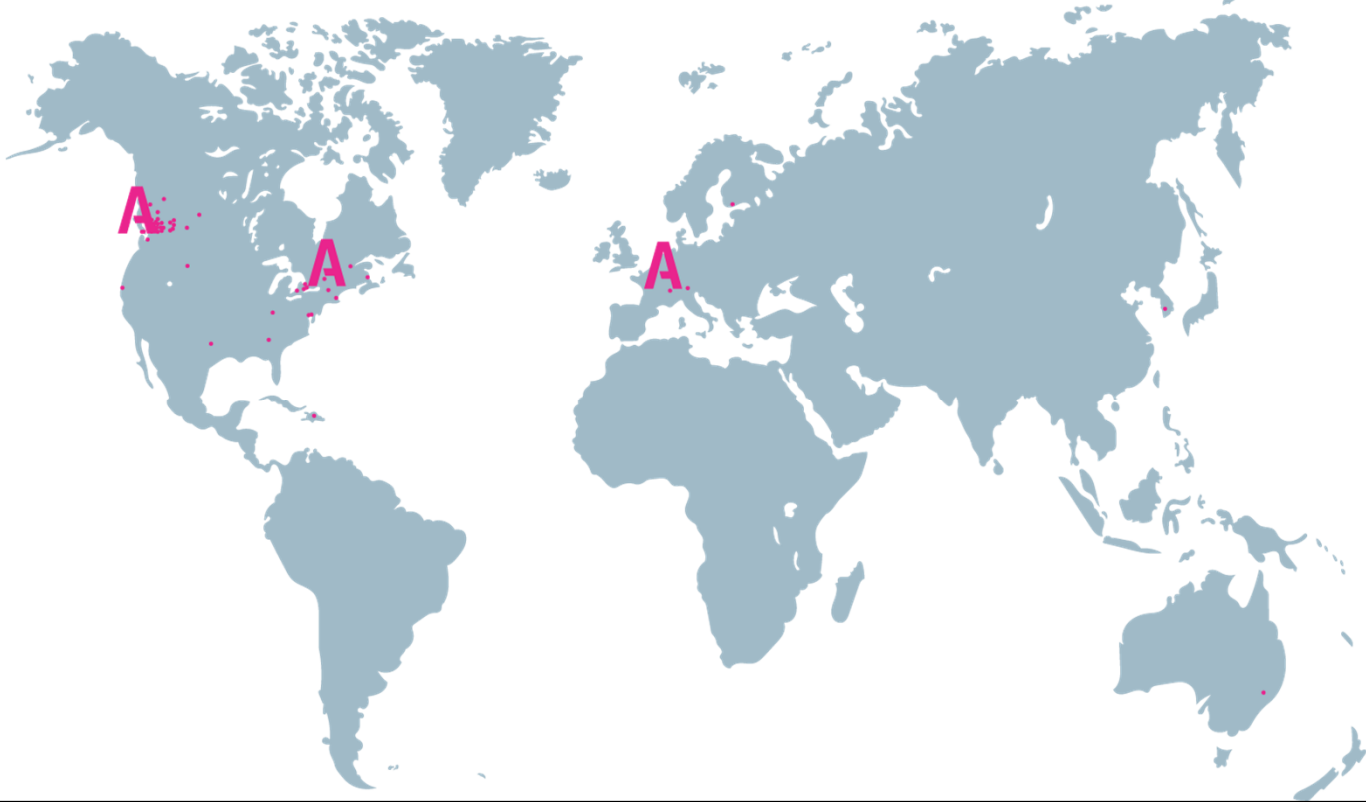

ÉQUIPE



40 et +

PROJETS



SOMMAIRE

- 1. ASSEMBLAGES DE DIAPHRAGMES**
- 2. BOIS BETON COLLABORANTS**
- 3. ASSEMBLAGES INNOVANTS**

SOMMAIRE

- 1. ASSEMBLAGES DE DIAPHRAGMES**
 - i. INTRODUCTION**
 - ii. PONTAGE ACIER SUR STRUCTURE DE BOIS**
 - iii. PONTAGE DE BOIS SUR STRUCTURE D'ACIER**

INTRODUCTION



INTRODUCTION

DONNÉES

- Localisation: Montreal, QC
- Usage: Édifice a bureaux
- Structure hybride ... très hybride
- Hauteur: 3 étages (14.6m)
- Pas de Niveau Inferieur (Sous-Sol)
- Importance: Normal
- Code: CNBC 2015
- Aucune Irrégularités (Séismique)

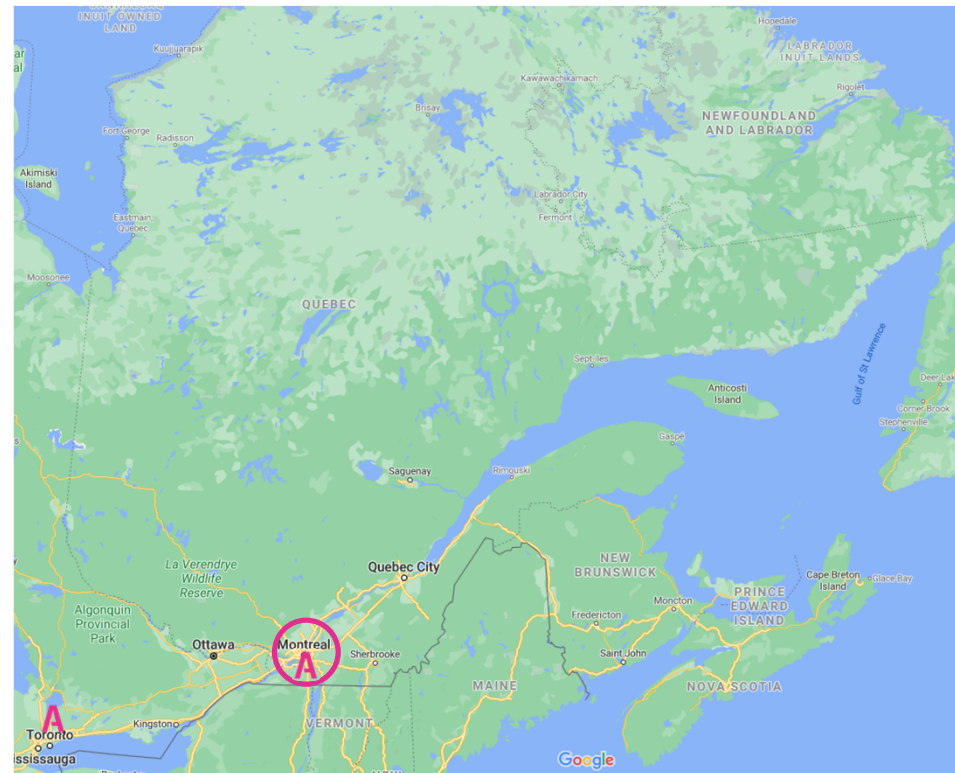

INTRODUCTION

GÉOMÉTRIE DU BATIMENT

- Hauteur: 3 étages (14.6m)
- 30.5m x 48.8m
- Grille de colonnes: 6.1m x 9.15m (20'x30')
- Poutres Primaires
- Poutre Secondaire @ 3.05m (10') OC
- Dalle
- Système Latéral

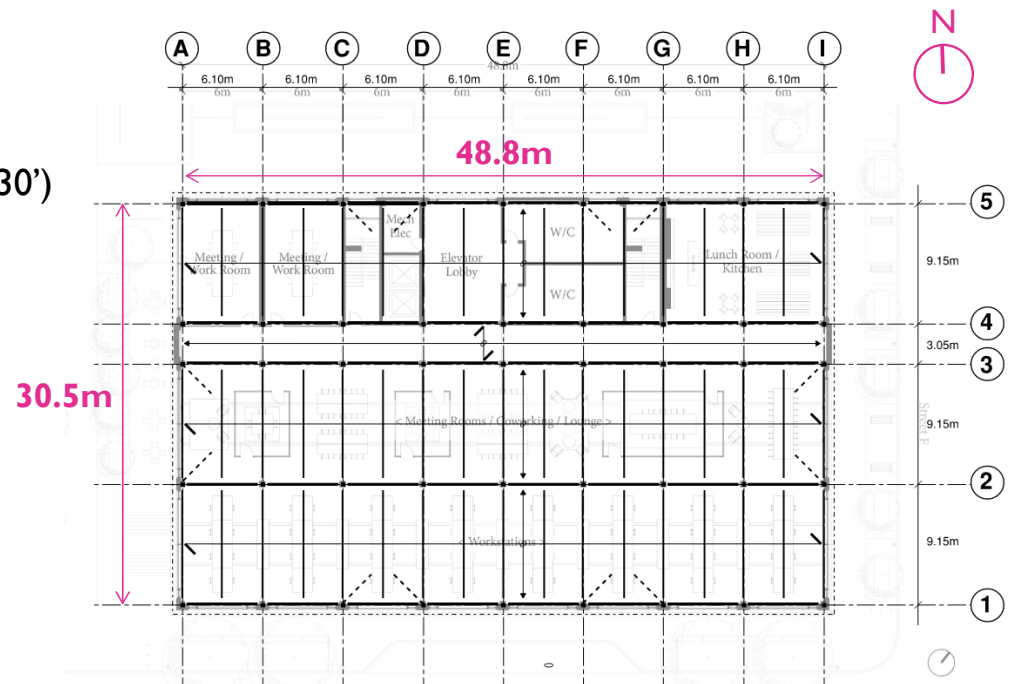

INTRODUCTION

GÉOMÉTRIE DU BATIMENT

- Hauteur: 3 étages (14.6m)
- 30.5m x 48.8m
- Grille de colonnes: 6.1m x 9.15m (20'x30')
- Poutres Primaires
- Poutre Secondaire @ 3.05m (10') OC
- Dalle
- Système Latéral

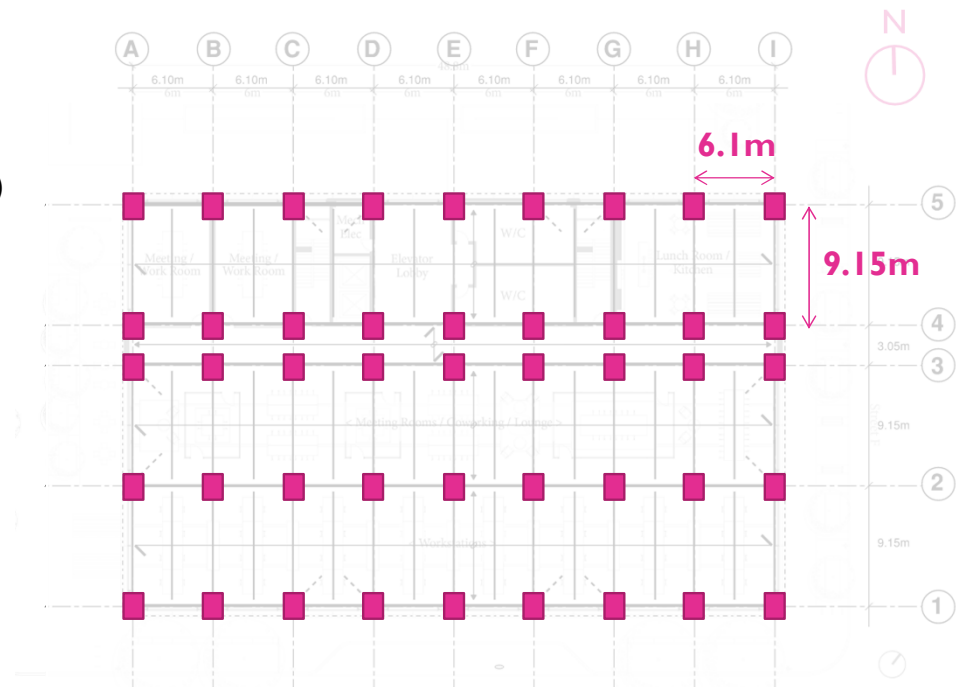

INTRODUCTION

GÉOMÉTRIE DU BATIMENT

- Hauteur: 3 étages (14.6m)
- 30.5m x 48.8m
- Grille de colonnes: 6.1m x 9.15m (20'x30')
- Poutres Primaires
- Poutre Secondaire @ 3.05m (10') OC
- Dalle
- Système Latéral

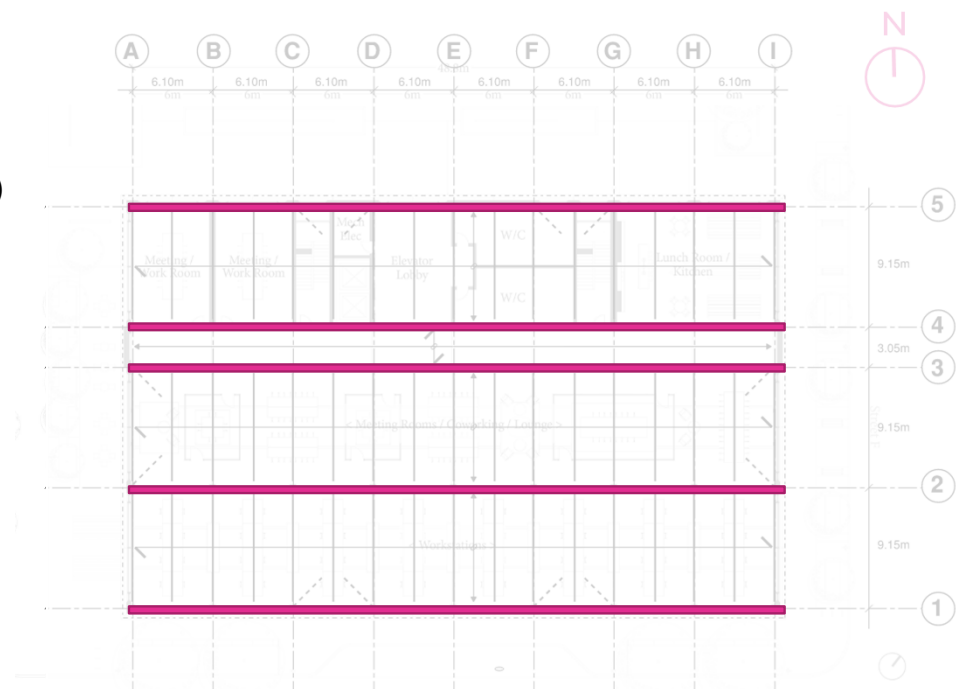

INTRODUCTION

GÉOMÉTRIE DU BATIMENT

- Hauteur: 3 étages (14.6m)
- 30.5m x 48.8m
- Grille de colonnes: 6.1m x 9.15m (20'x30')
- Poutres Primaires
- Poutre Secondaire @ 3.05m (10') OC
- Dalle
- Système Latéral

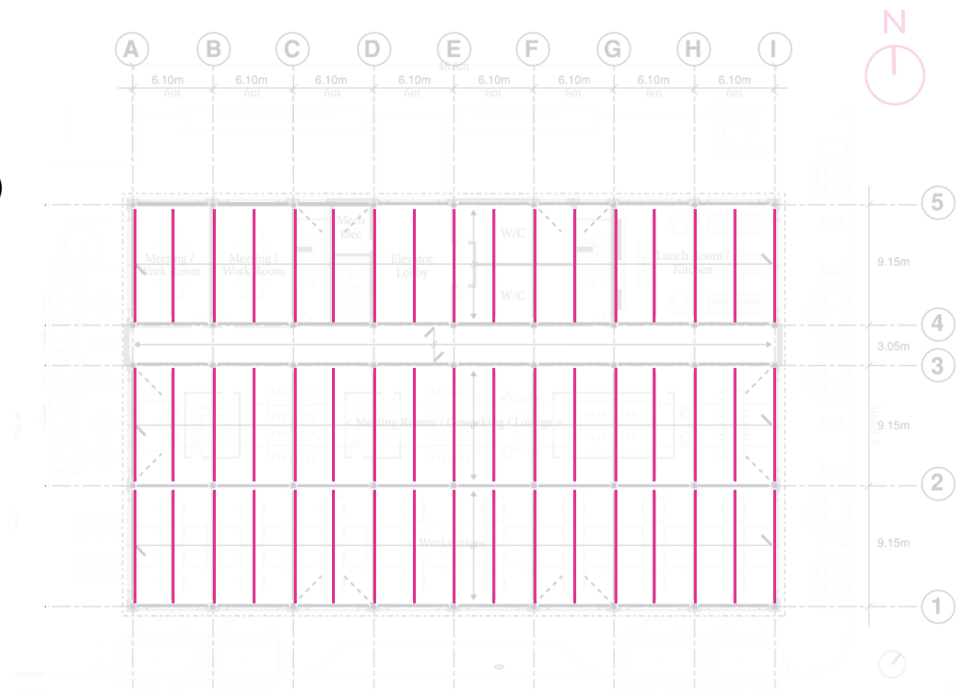

INTRODUCTION

GÉOMÉTRIE DU BATIMENT

- Hauteur: 3 étages (14.6m)
- 30.5m x 48.8m
- Grille de colonnes: 6.1m x 9.15m (20'x30')
- Poutres Primaires
- Poutre Secondaire @ 3.05m (10') OC
- Dalle
- Système Latéral
 - Ossature Ductile a contreventement limitant le flambement = BRB

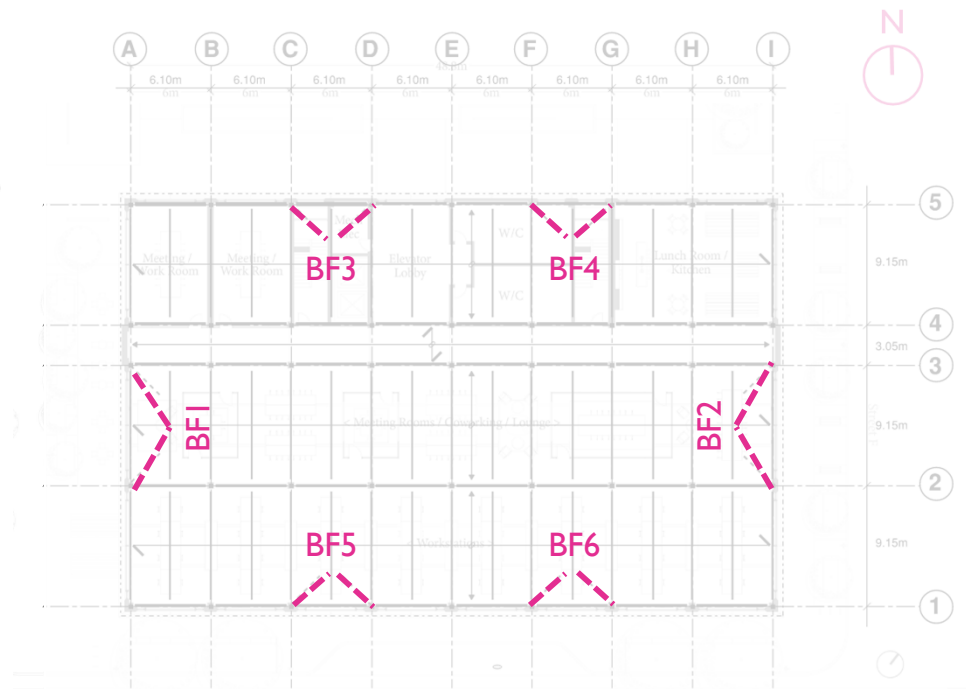

INTRODUCTION

DESCRIPTION DE LA CHARPENTE

- Toit: Pontage d'acier et poutre lamellé-collé
- L2 & L3: Pontage de bois sur poutre d'acier

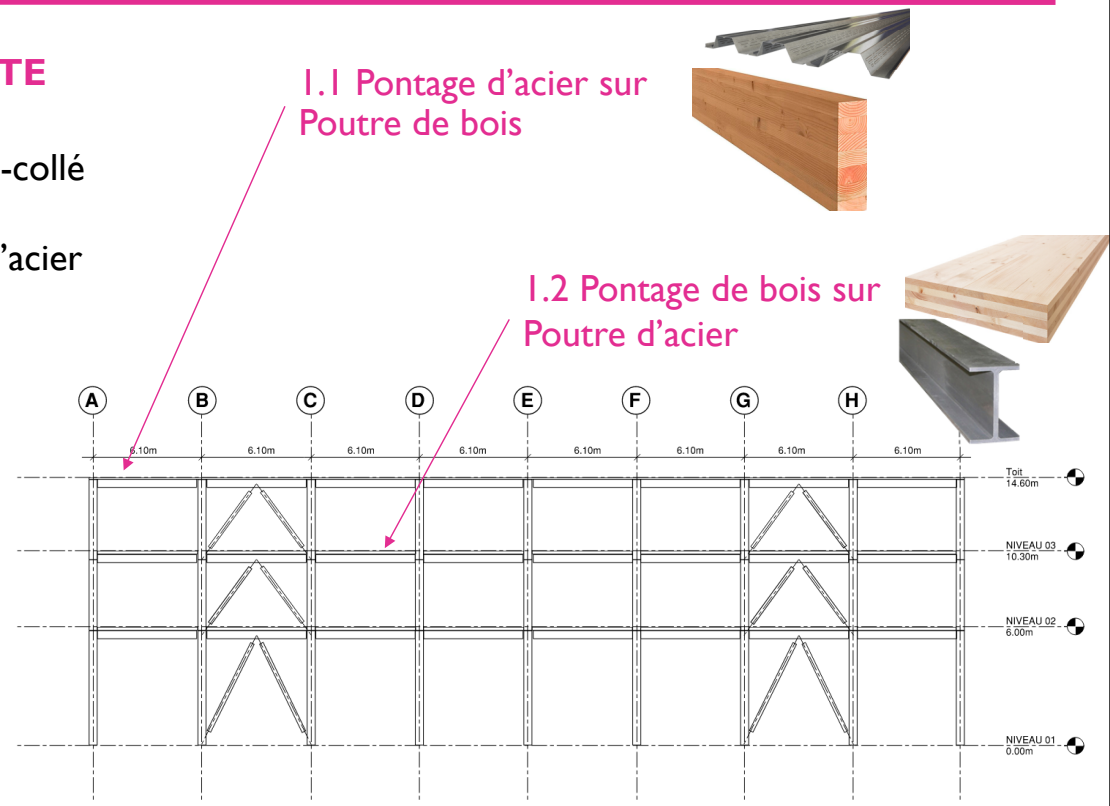

INTRODUCTION

CHARGES GRAVITAIRES

- Poids Propres:
 - Toit : 1.6 kPa
 - Planchers : 3.8 kPa
 - Murs Extérieurs : 1.0 kPa
- Charges vives
 - Toit : 1.0 kPa
 - Planchers (bureaux) : 2.4 kPa
- Charges de neige
 - Toit, $U_L S$: 2.5 kPa
 - Toit, $S_L S$: 2.2 kPa

CHARGES LATÉRALES

- Charge de Vent
 - $q_{1/50}$: 0.42 kPa
- Distribution Verticale

Toit	: 71.4 kN
L3	: 142.7 kN
L2	: 170.9 kN

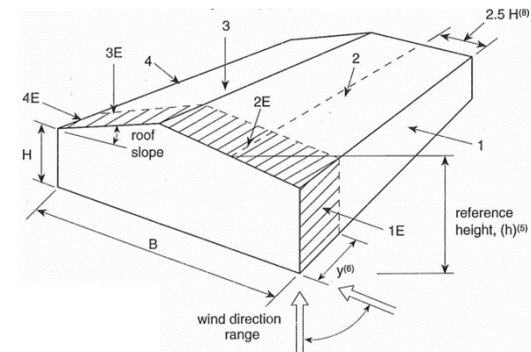

INTRODUCTION

CHARGES LATÉRALES (SUITE)

- Charge Séismique
 - Site de classe : C
 - Système Latéral : BRB
 - Rd : 4
 - Ro : 1.2
 - Ta (modèle) : 0.5
 - Vx = Vy : 996.2 kN
- Distribution Verticale
 - Toit : 382.8 kN
 - L3 : 384.2 kN
 - L2 : 229.2 kN

Site Information

Province: Quebec
 City: Montreal (City Hall)
 Site Class: Site Class C
 Importance Category: Normal
 SFES Material: Steel
 SFES: Ductile buckling-restrained braced frames

Building Information

Building Height (H_t): 14.6 m
 Storeys Above Grade (N): 3
 Weight of Structure (W_t): 15375 kN

Maximum allowed height (m) of the SFES system: 40

Design Spectral Response Acceleration

T ≤ 0.2	0.5950 g
T = 0.5	0.3110 g
T = 1.0	0.1480 g
T = 2.0	0.0680 g
T = 5.0	0.0347 g
T = 10.0	0.0206 g

Spectral acceleration of fundamental period: 0.311

Higher Mode Effects

SO(2)(S10): 33.2256
 PGA_{max}: 0.3032 g

Manual Input

S _v (0.2)	S _v (0.5)	S _v (1.0)	S _v (2.0)	S _v (5.0)	S _v (10.0)	PGA	PGV
0.0970	0.0840	0.0740	0.0520	0.0190	0.0720	0.0420	0.0990

Automatic Input

S _v (0.2)	S _v (0.5)	S _v (1.0)	S _v (2.0)	S _v (5.0)	S _v (10.0)	PGA	PGV
0.5950	0.3110	0.1480	0.0680	0.0180	0.0062	0.3790	0.2550

Site Coefficients

F(0.2)	F(0.5)	F(1.0)	F(2.0)	F(5.0)	F(10.0)	F(PGA)	F(PGV)
1.0000	1.0000	1.0000	1.0000	1.0000	1.0000	1.0000	1.0000

Site Class: C

Importance Factor: I_e = 1
 R_d = 4, R_o = 1.2

Design Spectral Response Acceleration Graph

Lateral Fundamental Period

Type of building: Braced Frames

Empirical Formula: 4.1.8.11.3(a) 4.1.8.11.4: $T_n = 0.028 A_s$

Manual Input: 4.1.8.11.3(d): 0.500

Design Lateral Earthquake Force of the Base

4.1.8.11.2) $V = S(T) M_e W / (R_d R_o) = 0.045 W$ or 996 kN

4.1.8.11.2(b) $V_{min} = S(2.0) M_e W / (R_d R_o) = 0.014 W$ or 218 kN

4.1.8.11.2(c) $V_{near} = \text{MAX} \left[\frac{2(0.2)g W}{R_d R_o}, \frac{S(0.5)g W}{R_d R_o} \right] = 0.083 W$ or 1271 kN

Minimum Lateral Seismic Force: 4.1.8.11.2) 0.062 W or 996 kN

Storeys	h _x (m)	W _x (kN)	h _x W _x (kN-m)	F _x (kN)	F _x (kN)	V _{storey} (kN)
Roof	14.6	3963	57856.15	0.0	382.8	382.8
3	10.3	5638	58071.4	0.0	384.2	767.0
2	6	5774	34644	0.0	229.2	996.2
Ground	0	0	0	0.0	0.0	0.0
Total:		15374.75	150571.55	0.00	996.2	

EXEMPLE 1.1

DIAPHRAGME ACIER SUR STRUCTURE DE BOIS

PORTÉE DE L'EXEMPLE

- DIAPHRAGME DE TOIT → TYPE "FLEXIBLE"
- FORCES SEULEMENT DANS LA DIRECTION N/S
- **CONCEPTION DE LA CONNEXION PONTAGE D'ACIER AUX COLLECTEURS DE BOIS**
- PAS DE CALCUL DE DEFLECTION DU DIAPHRAGM (BIEN CONNU)
- PAS DE CONNEXION INTERNE DU DIAPHRAGME D'ACIER (BIEN CONNU)

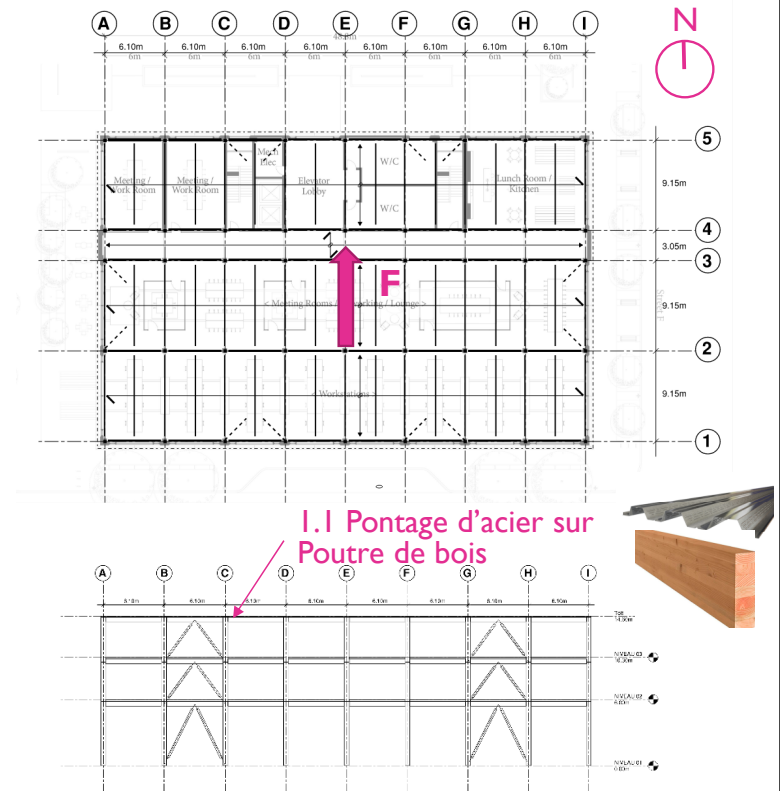

EXEMPLE 1.1

DIAPHRAGME ACIER SUR STRUCTURE DE BOIS

FORCES DE DESIGN DU DIAPHRAGME (TOIT)

Type de Charge	Combinaison de charge	Ajustement (coefficient de surcapacité γ_i)
Vent		
• $F_W = 71.4 \text{ Kn}$	$\times 1.4 = 100.0 \text{ kN}$	
Seismic		
• $F_{EQ} = 382.8 \text{ kN}$	$\times 1.0 = 382.8 \text{ kN}$	$\times 2.0 = 765.6 \text{ kN}$
• $F_{EQ,min} = 332.1 \text{ kN}$	$\times 1.0 = 332.1 \text{ kN}$	$\times 2.0 = 664.2 \text{ kN}$

VOIR ANNEXE POUR AJUSTEMENT DES FORCES SEISMIQUES POUR CAPACITE DU SFRS

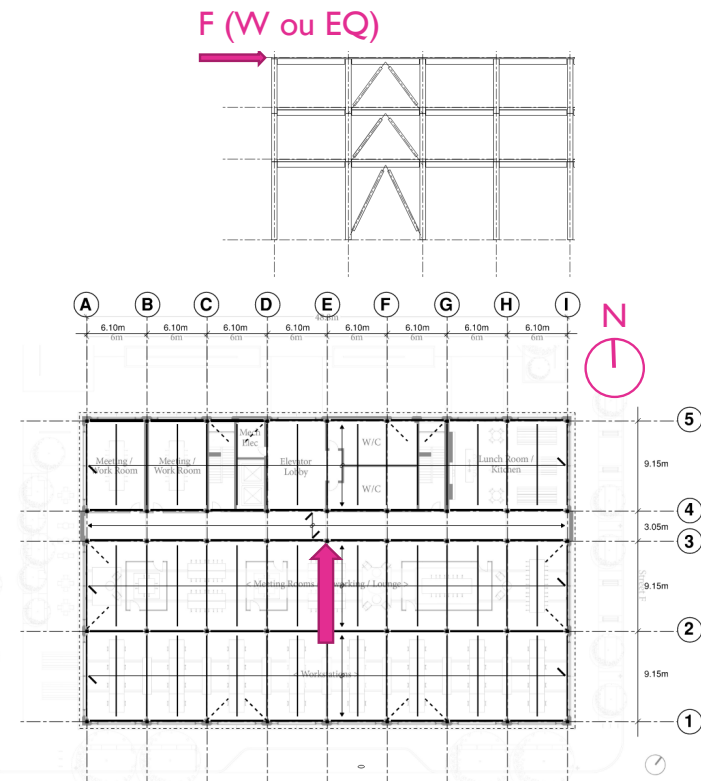

EXEMPLE 1.1

DIAPHRAGME ACIER SUR STRUCTURE DE BOIS

FORCES DE DESIGN DU DIAPHRAGME

Centrée

- $R_A = R_B = 765.6 / 2 = 382.8 \text{ kN}$

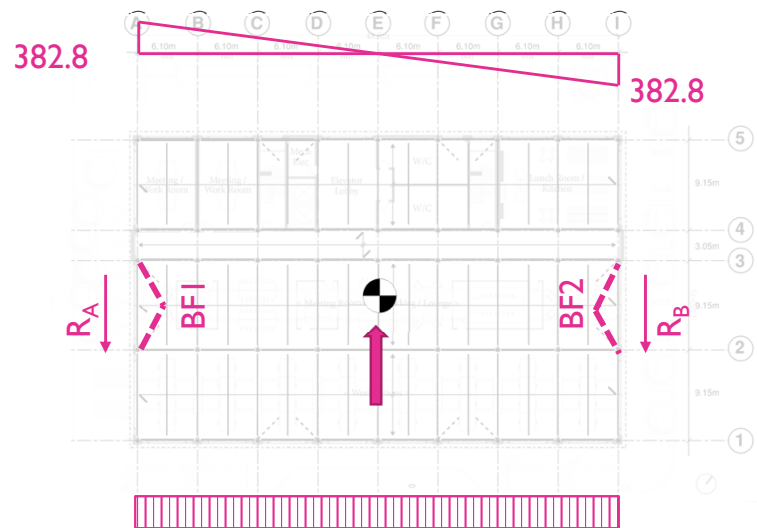

Excentricité accidentelle (10%)

- $R_{A,+10\%} = R_{B,+10\%} = 765.6 \times 0.6 = 459.4 \text{ kN}$
- $R_{A,-10\%} = R_{B,-10\%} = 765.6 \times 0.4 = 306.2 \text{ kN}$

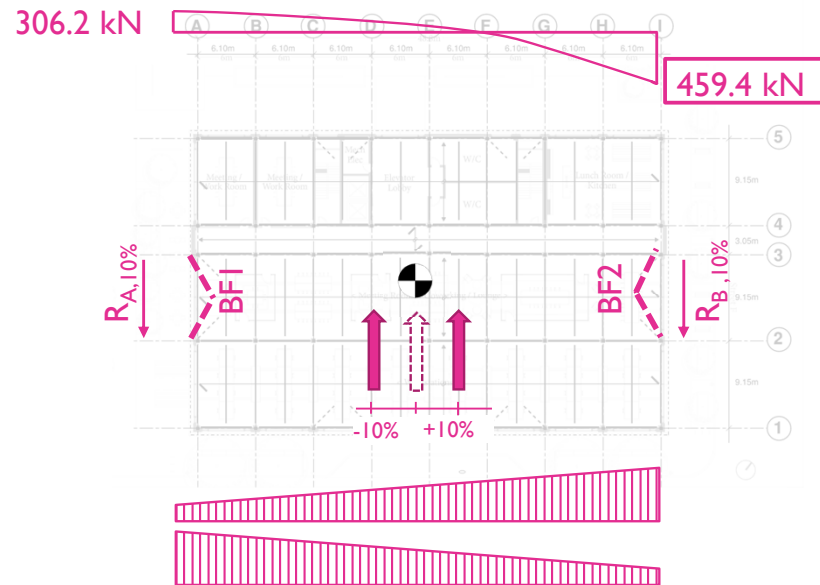

EXEMPLE 1.1

DIAPHRAGME ACIER SUR STRUCTURE DE BOIS

FORCES DE DESIGN DU DIAPHRAGME

Cisaillement longitudinale

- $R_{A,max} = R_{B,max} = 459.4 \text{ kN}$
- $v_F = 459.4 / 30.5 = 15.1 \text{ kN/m}$

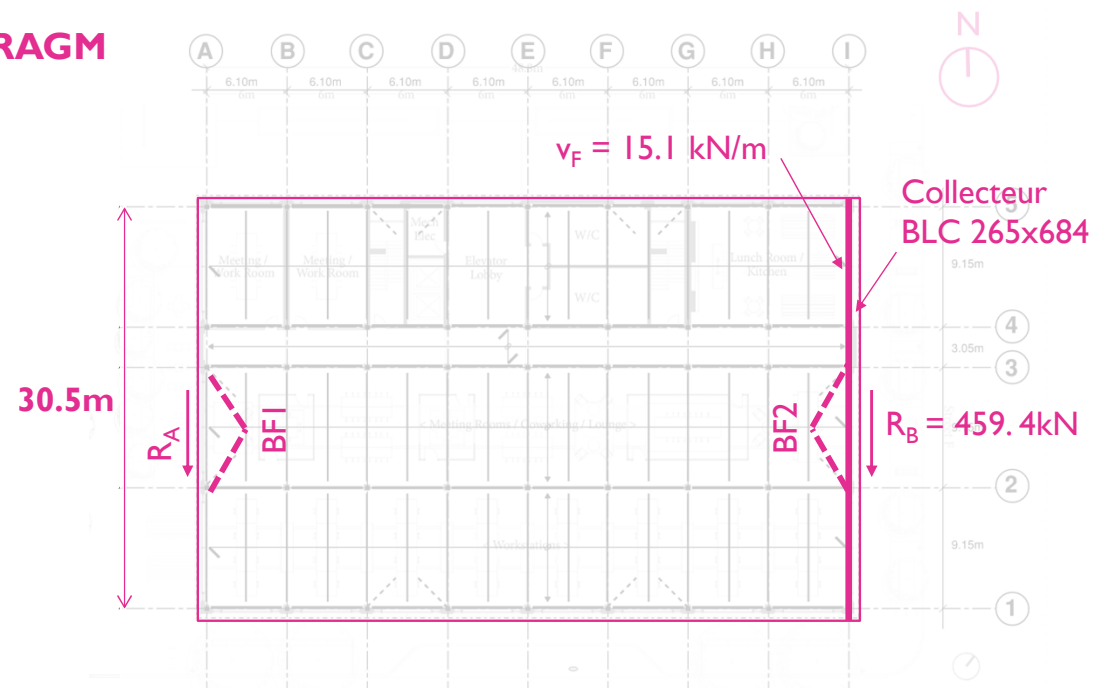

EXEMPLE 1.1

DIAPHRAGME ACIER SUR STRUCTURE DE BOIS

CONCEPTION DE LA CONNECTION

- $v_F = 15.1 \text{ kN/m}$
- Connexion de type "vis"



$v_F = 15.1 \text{ kN/m}$



VÉRIFICATIONS (2)

1.0 RÉSISTANCE CISAILLEMENT LONGITUDINAL DU DIAPHRAGME D'ACIER, S_n (NORME AISI S310-16)

$$\phi S_n = \min(\phi_{df} S_{nf}, \phi_{db} S_{nb})$$

- A. RÉSISTANCE CISAILLEMENT LONGITUDINALE CONTROLÉ PAR LES CONNEXIONS, S_{nf}
- B. RÉSISTANCE EN CISAILLEMENT LONGITUDINALE CONTROLÉ PAR LE FLAMBAGE DU PONTAGE D'ACIER, S_{nb}

2.0 RÉSISTANCE LATÉRALE A L'ENFONCEMENT – CSA O86-14 (CL. 12.1 I VIS A BOIS)

EXEMPLE 1.1

DIAPHRAGME ACIER SUR STRUCTURE DE BOIS

I.0 RÉSISTANCE CISAILLEMENT LONGITUDINAL DU DIAPHRAGME D'ACIER, S_n (NORME AISI S310-16)

$$\phi S_n = \min(\phi_{df} S_{nf}, \phi_{db} S_{nb})$$

A. RÉSISTANCE CISAILLEMENT LONGITUDINALE CONTROLÉ PAR LES CONNEXIONS, S_{nf}

A.1 Résistance cisaillement longitudinal – connexions aux supports, S_{ni}

A.2 Résistance cisaillement longitudinal - connexions aux coins, S_{nc}

A.3 Résistance cisaillement longitudinal - connexions en rive/bordure parallèle aux panneaux, S_{ne}

B. RÉSISTANCE EN CISAILLEMENT LONGITUDINALE CONTROLÉ PAR LE FLAMBAGE DU PONTAGE D'ACIER, S_{nb}

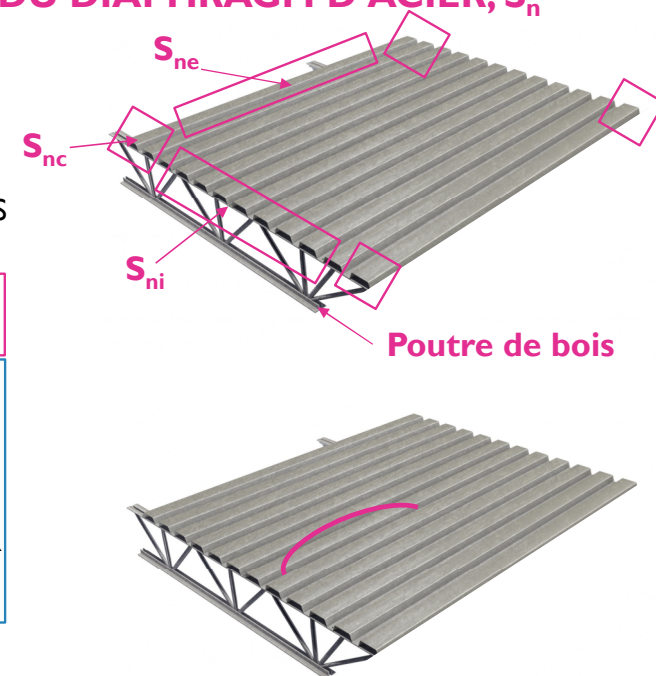

EXEMPLE 1.1

DIAPHRAGME ACIER SUR STRUCTURE DE BOIS

1.0 RÉSISTANCE CISAILLEMENT LONGITUDINAL DU DIAPHRAGME D'ACIER, S_n (NORME AISI S310-16)

ÉLÉMENT DE LA CONNECTION

Élément #1:

Pontage d'acier ASTM A 653M SS Grade 230
 Profondeur, $D_d = 75\text{mm}$
 $F_y = 230\text{ MPa}$
 $F_{u1} = F_{u2} = 310\text{ MPa}$
 $t_1 = t_2 = 1.52\text{mm}$ (Gage 16)
 $I = 2,294,846\text{ mm}^4/\text{m}$
 $E = 200,000\text{ MPa}$
 Largeur de panneau = 610mm
 Longueur de panneau, $L = 9150\text{mm}$
 Portee entre support, $L_v = 3050\text{mm}$

Élément #2

Poutre Glulam D.Fir 24f-E
 $G = 0.49$

Connecteur aux supports

Patron de vissage: 24/7
 Vis #14 x 75mm (3")
 Diamètre (d) = 6.3mm
 Longueur (L) = 75mm

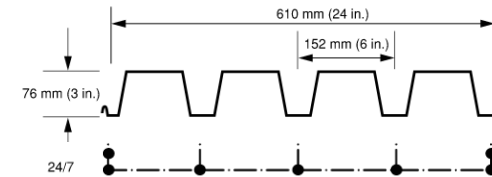

Connecteur aux "sidelap"

Vis #14
 Diamètre (d) = 6.3mm
 Espacement = 75mm

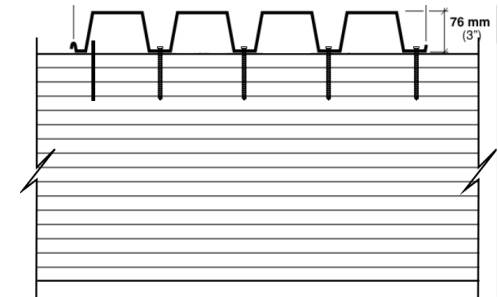

EXEMPLE 1.1

DIAPHRAGME ACIER SUR STRUCTURE DE BOIS

1.0 RÉSISTANCE CISAILLEMENT LONGITUDINAL DU DIAPHRAGME D'ACIER, S_n (NORME AISI S310-16)

- Résistance cisaillement d'un connecteur au support, P_{nf}

$$P_{nf} = \min(P_{nfw}, P_{nfws}, P_{nss})$$

$$P_{nfw} = 8.76 \cdot G = 4.3kN$$

$$P_{nfws} = 2.7 \cdot t_1 \cdot d \cdot F_{u1} = 8.02kN$$

$$P_{nss} = 12.01kN$$

$$P_{nf} = 4.3kN$$

- Résistance cisaillement d'un connecteur au "sidelap", P_{ns}

$$P_{ns} = \min(P_{nsw}, P_{nsws}, P_{nss})$$

$$P_{nfw} = 4.2 \cdot (t_2^3 \cdot d)^{0.5} \cdot F_{u2} = 6.12kN$$

$$P_{nfws} = 2.7 \cdot t_1 \cdot d \cdot F_{u1} = 8.02kN$$

$$P_{nss} = 12.01kN$$

$$P_{ns} = 6.12kN$$

- A.1 Résistance cisaillement longitudinal contrôlée par les connexions (panneaux internes ou de rive), S_{ni}

$$S_{ni} = [2 \cdot A(\lambda - 1) + \beta] \cdot \frac{P_{nf}}{L}$$

$$A = 2 \text{ (nb. connecteurs par flutes)}$$

$$\lambda = 1 - \frac{D \cdot L_v}{369 \cdot \sqrt{t}} \geq 0.7$$

$$\lambda = 0.7$$

$$\beta = n_s \cdot a_s + 2 \cdot n_p \cdot a_p^2 + 4a_e^2$$

$$n_s = 3 \cdot L_v / s, \text{ sidelap} = 3 \cdot \frac{3050}{75} = 122$$

$$a_s = P_{ns} / P_{nf} = 6.12 / 4.3 = 1.43$$

$$a_p^2 = a_e^2 = \left(\frac{1}{w^2}\right) \sum x_p^2 = 2.5$$

$$n_p = \frac{L}{L_v} - 1 = 2$$

$$\beta = 122 \cdot 1.43 + 2 \cdot 2 \cdot 2.5 + 4 \cdot 2.5 = 194.06$$

$$S_{ni} = [2 \cdot 1(0.7 - 1) + 194.46] \cdot \frac{4.3}{9.15} = 90.5kN/m$$

EXEMPLE 1.1

DIAPHRAGME ACIER SUR STRUCTURE DE BOIS

1.0 RÉSISTANCE CISAILLEMENT LONGITUDINAL DU DIAPHRAGME D'ACIER, S_n (NORME AISI S310-16)

- A.2 Résistance cisaillement longitudinal contrôlée par les connexions de coin (panneaux internes ou de rive), S_{nc}

$$S_{nc} = \sqrt{\frac{N^2 \cdot \beta^2}{L^2 \cdot N^2 + \beta^2}} \cdot P_{nf}$$

$$N = \frac{5}{0.61} = 8.196 \text{ (nb. connecteurs eff./m)}$$

$$L = 9.15$$

$$\beta = 194.06 \text{ (voir calcul } S_{ni} \text{, page précédente)}$$

$$P_{nf} = 4.3 \text{ kN (voir page précédente)}$$

$$S_{nc} = \sqrt{\frac{8.196^2 \cdot 194.46^2}{9.15^2 \cdot 8.196^2 + 194.46^2}} \cdot 4.3$$

$$S_{nc} = 32.2 \text{ kN/m}$$

- A3 Résistance cisaillement longitudinal contrôlée par les connexions en rive/bordure parallèle des panneaux, S_{ne}

$$S_{ne} = \frac{(2 \cdot a_1 + n_p \cdot a_2) \cdot P_{nf} + n_p \cdot P_{nfs}}{L}$$

$$S_{ne} = 100.7 \text{ kN/m}$$

Calcul à l'aide du logiciel Hilti profis diaphragme

- B Résistance cisaillement longitudinal contrôlée par le flambage des panneaux, S_{nb}

$$S_{nb} = \frac{7890}{\alpha L_v^2} \left(\frac{I_{xg}^3 t^3 d}{s} \right)^{0.25}$$

$$S_{nb} = 181.0 \text{ kN/m}$$

Calcul à l'aide du logiciel Hilti profis diaphragme

EXEMPLE 1.1

DIAPHRAGME ACIER SUR STRUCTURE DE BOIS

1.0 RÉSISTANCE CISAILLEMENT LONGITUDINAL DU DIAPHRAGME D'ACIER, S_n (NORME AISI S310-16)

- Résistance cisaillement longitudinal contrôlée par les connexions, S_{nf}

$$\phi S_{nf} = \min(\phi S_{ni}, \phi S_{nc}, \phi S_{ne})$$

$$\phi S_{ni} = 0.55 \cdot 90.76 = 49.92 \text{ kN/m}$$

$$\phi S_{nc} = 0.55 \cdot 32.2 = 17.7 \text{ kN/m}$$

$$\phi S_{ne} = 0.55 \cdot 100.7 = 55.4 \text{ kN/m}$$

$$\phi S_{nf} = 17.7 \text{ kN/m}$$

- Résistance cisaillement longitudinal contrôlée par le flambage du pontage, S_{nb}

$$\phi S_{nb} = 0.75 \cdot 181.0 = 135.7 \text{ kN/m}$$

- Résistance cisaillement longitudinal du diaphragme, ϕS_n

$$\phi S_n = \min(\phi S_{nf}, \phi S_{nb}) = 17.7 \text{ kN/m} \geq v_F = 15.1 \text{ kN/m} \quad \text{OK!}$$

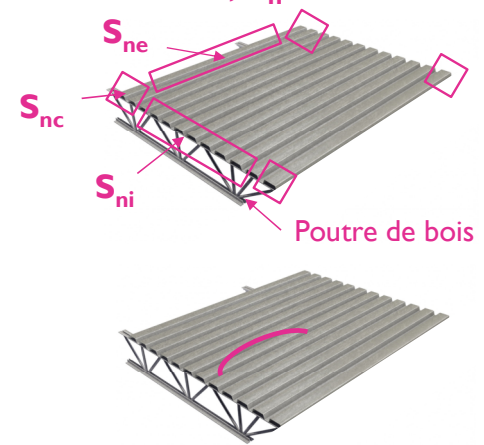

Table B1.1-1
Safety Factors and Resistance Factors for Diaphragms

Load Type or Combinations Including	Connection Type	Limit State					
		Connection-Related			Stability-Related		
		Ω_d (ASD)	ϕ_d (LRFD)	ϕ_d (LSD)	Ω_d (ASD)	ϕ_d (LRFD)	ϕ_d (LSD)
Wind	Welds	2.15	0.75	0.60	2.00	0.80	0.75
	Screws	2.00	0.80	0.75			
Earthquake and All Others	Welds	3.00	0.55	0.40	2.00	0.80	0.75
	Screws	2.30	0.70	0.55			

EXEMPLE 1.1

DIAPHRAGME ACIER SUR STRUCTURE DE BOIS

2.0 RESISTANCE LATERALE A L'ENFONCEMENT – CSA O86 (CL. 12.1 I VIS A BOIS)

- Resistance Rupture Ductile, N_r

$$N_r = \phi_y \cdot N_u \cdot n_F \cdot n_s \cdot J_A \cdot J_E$$

$$\phi_y = 0.8$$

$$n_F = 1$$

$$n_s = 1$$

$$J_A = 1 \rightarrow \text{Pas de vissage en biais}$$

$$J_E = 1 \rightarrow \text{Pas de connecteur installé en fil de bout}$$

Calcul de N_u

$$N_u = n_u \cdot (K_D \cdot K_{SF} \cdot K_T)$$

$$K_D = 1.15 \rightarrow \text{Courte Durée (EQ)}$$

$$K_{SF} = 1 \rightarrow \text{Bois Sec } (\leq 19\%) \text{ en Milieu Sec}$$

$$K_T = 1 \rightarrow \text{Pas de traitement de préservation ou d'ignifugation}$$

$$n_u = \text{voir prochaine page}$$

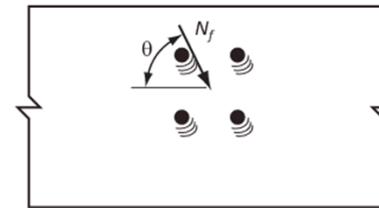

Yielding

$$N_r = \phi N_u n_F n_s J_A J_E$$

where

$$\phi = 0.8$$

$$N_u = n_u (K_D K_{SF} K_T)$$

where

n_u = unit lateral strength resistance, N (Clause 12.11.4.2)

n_F = number of fasteners in the connection

n_s = number of shear planes per screw

J_A = toe-screwing factor

= 0.83 where screws are started at approximately one-third the screw length from the end of and driven at an angle of about 30° to the grain of the member

= 1.0 in all other cases

J_E = factor for fastening into end grain

= 0.67 in end grain

= 1.0 in all other cases

EXEMPLE 1.1

DIAPHRAGME ACIER SUR STRUCTURE DE BOIS

I.0 RESISTANCE LATERALE A L'ENFONCEMENT – CSA O86 (CL. 12.11 VIS A BOIS)

- Resistance Rupture Ductile, N_r (suite)

Calcul de n_u

$$d_F = 6.3 \text{ mm}$$

$$t_1 = 1.52 \text{ mm}$$

$$t_2 = 75 - 1.52 = 73.48 \text{ mm}$$

$$f_1 = K_{sp} \cdot (\phi_{steel} / \phi_{wood}) \cdot f_u$$

$$f_1 = 2.7 \cdot (0.4 / 0.8) \cdot 310$$

$$f_1 = 418.5 \text{ MPa}$$

$$f_2 = 50 \cdot G \cdot (1 - 0.01 \cdot d_F)$$

$$f_2 = 50 \cdot 0.49 \cdot (1 - 0.01 \cdot 6.14)$$

$$f_2 = 23.0 \text{ MPa}$$

$$f_3 = 110 \cdot G^{1.8} \cdot (1 - 0.01 \cdot d_F)$$

$$f_3 = 110 \cdot 0.49^{1.8} \cdot (1 - 0.01 \cdot 6.14)$$

$$f_3 = 28.6 \text{ MPa}$$

$$f_y = 550 \text{ MPa}$$

For steel side plates:

f_1 = embedment strength of steel side plate, MPa

$$= K_{sp} (\phi_{steel} / \phi_{wood}) f_u$$

where

K_{sp} = 3.0 for mild steel meeting the requirements of CSA G40.21 or ASTM A36/A36M

= 2.7 for light gauge steel

ϕ_{steel} = resistance factor for steel member in wood screw connection

= 0.67 for mild steel meeting the requirements of CSA G40.21 or ASTM A36/A36M

= 0.4 for light gauge steel

ϕ_{wood} = resistance factor for wood member in wood screw connection

= 0.8

f_u = ultimate tensile strength of steel

= 400 MPa for ASTM A36/A36M steel

= 450 MPa for CSA G40.21 steel, Grades 300W and 350W

= 310 MPa for light gauge steel, Grades SQ230 and higher

t_1 = head-side member thickness for two-member connections, mm

= minimum side plate thickness for three-member connections, mm (Clause 12.11.2.3)

f_2 = embedment strength of main member where failure is wood bearing, MPa

$$= 50 G (1 - 0.01 d_F)$$

where

G = mean relative density of lumber or glulam member (see Table A.12.1)

t_2 = length of penetration into point-side member for two-member connections, mm

= centre member thickness for three-member connections, mm (Clause 12.11.2.3)

f_3 = embedment strength of main member where failure is fastener yielding, MPa

$$= 110 G^{1.8} (1 - 0.01 d_F)$$

f_y = wood screw yield strength, MPa (Table 12.11.1)

EXEMPLE 1.1

DIAPHRAGME ACIER SUR STRUCTURE DE BOIS

I.0 RESISTANCE LATERALE A L'ENFONCEMENT – CSA O86 (CL. 12.1 | VIS A BOIS)

- Resistance Rupture Ductile, N_r (suite)

Calcul de n_u

$$d_F = 6.3 \text{ mm}$$

$$t_1 = 1.52 \text{ mm}$$

$$t_2 = 75 - 1.52 = 73.48 \text{ mm}$$

$$f_1 = K_{sp} \cdot (\Phi_{steel} / \Phi_{wood}) \cdot f_u$$

$$f_1 = 2.7 \cdot (0.4 / 0.8) \cdot 310$$

$$f_1 = 418.5 \text{ MPa}$$

$$f_2 = 50 \cdot G \cdot (1 - 0.01 \cdot d_F)$$

$$f_2 = 50 \cdot 0.49 \cdot (1 - 0.01 \cdot 6.14)$$

$$f_2 = 23.0 \text{ MPa}$$

$$f_3 = 110 \cdot G^{1.8} \cdot (1 - 0.01 \cdot d_F)$$

$$f_3 = 110 \cdot 0.49^{1.8} \cdot (1 - 0.01 \cdot 6.14)$$

$$f_3 = 28.6 \text{ MPa}$$

$$f_y = 550 \text{ MPa}$$

(a) $f_1 d_1 t_1$



$$n_u \text{ (a)} = 4.0 \text{ kN}$$

(b) $f_1 d_1 t_2$



$$n_u \text{ (b)} = 10.6 \text{ kN}$$

(c) $\frac{1}{2} f_2 d_1 t_2$

(d) $f_1 d_1^2 \left(\sqrt{\frac{1}{6} \frac{f_1}{(f_1 + f_2)} \frac{f_2}{f_1} + \frac{1}{5} \frac{f_1}{d_1}} \right)$



$$n_u \text{ (d)} = 2.8 \text{ kN}$$

(e) $f_1 d_1^2 \left(\sqrt{\frac{1}{6} \frac{f_1}{(f_1 + f_2)} \frac{f_2}{f_1} + \frac{1}{5} \frac{f_2}{d_1}} \right)$



$$n_u \text{ (e)} = 40.7 \text{ kN}$$

(f) $f_1 d_1 \frac{1}{5} \left(\frac{f_1}{d_1} + \frac{f_2}{f_1} \frac{f_2}{d_1} \right)$



$$n_u \text{ (f)} = 2.9 \text{ kN}$$

(g) $f_1 d_1^2 \sqrt{\frac{2}{3} \frac{f_1}{(f_1 + f_2)} \frac{f_2}{f_1}}$



$$n_u \text{ (g)} = 3.9 \text{ kN}$$

EXEMPLE 1.1

DIAPHRAGME ACIER SUR STRUCTURE DE BOIS

I.0 RESISTANCE LATERALE A L'ENFONCEMENT – CSA O86 (CL. 12.1 | VISA BOIS)

- Resistance Rupture Ductile, N_r
- Nombre de Connecteurs requis par feuille (610mm)

Calcul de N_u

$$N_u = n_u \cdot (K_D \cdot K_{SF} \cdot K_T) \quad n_u = 2.8$$

$$N_u = 2.8 \cdot (1.15 \cdot 1 \cdot 1) \quad K_D = 1.15$$

$$N_u = 3.3 \text{ kN} \quad K_{SF} = 1$$

$$\quad \quad \quad K_T = 1$$

$$N_r = \phi_y \cdot N_u \cdot n_F \cdot n_S \cdot J_A \cdot J_E$$

$$N_r = 0.8 \cdot 3.3 \cdot 1 \cdot 1 \cdot 1 \cdot 1$$

$$N_r = 2.61 \text{ kN}$$

$$v_F = 15.1 \text{ kN/m}$$

$$v_{F,610} = 15.1 \cdot 0.61 = 9.2 \text{ kN}$$

$$n \geq v_{F,610} / N_r$$

$$n \geq 9.2 / 2.61$$

$$n \geq 3.5 \text{ vis}$$

EXEMPLE 1.1

DIAPHRAGME ACIER SUR STRUCTURE DE BOIS

SOMMAIRE - CONCEPTION DE LA CONNECTION

1.0 RESISTANCE CISAILLEMENT PONTAGE D'ACIER – AISI S310-16

- 7 vis requises – patron 24/7

2.0 RESISTANCE LATERALE A L'ENFONCEMENT – CSA O86 (CL. 12.11 VIS A BOIS)

- 3.5 vis requises

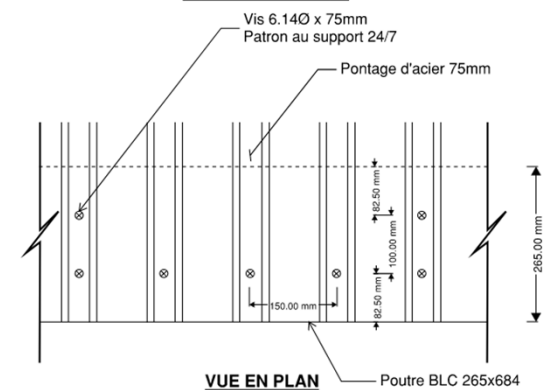
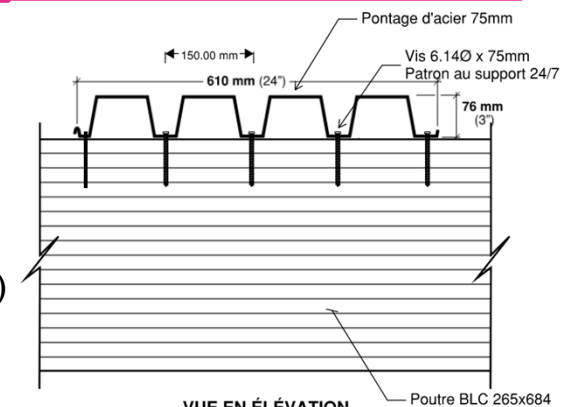

EXEMPLE 1.1

DIAPHRAGME ACIER SUR STRUCTURE DE BOIS

VERIFICATION DE L'ESPACEMENT DES CONNECTEURS

- Espacement maximale selon fournisseur pontage d'acier

Maximum Connector Spacing

	Connector at support	Connector at side-lap
Roof Deck	Every 300 mm (12 in.)	Every 900 mm (36 in.)
Floor Deck	Every 300 mm (12 in.)	Every 600 mm (24 in.)

OK!

- Espacement maximale selon code CSA O86

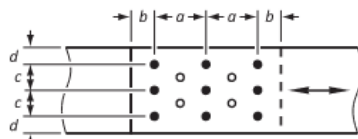

**Table 12.9.2.1
Minimum spacings for nails and spikes**

Dimension*	Minimum spacing (nail diameters)	
	Douglas Fir-Larch, Hem-Fir, and Western Cedar	Spruce-Pine-Fir and Northern Species
a — Spacing parallel to grain	20	16
b — End distance parallel to grain	15	12
c — Spacing perpendicular to grain	10	8
d — Edge distance perpendicular to grain	5	4

*See Figure 12.9.2.1.

	Espacement minimal	Espacement present
a	20x6.3=126mm	150mm
c	10x6.3=63mm	100mm
d	5x6.3 = 31.5mm	82.5mm

OK!

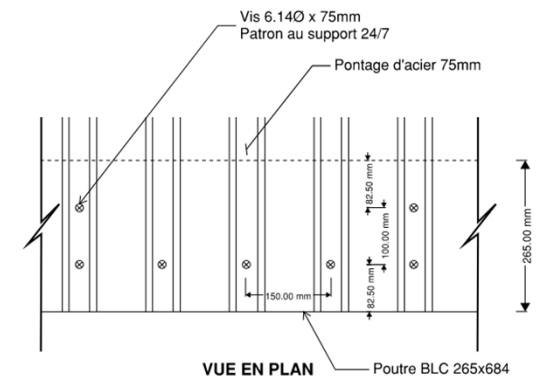
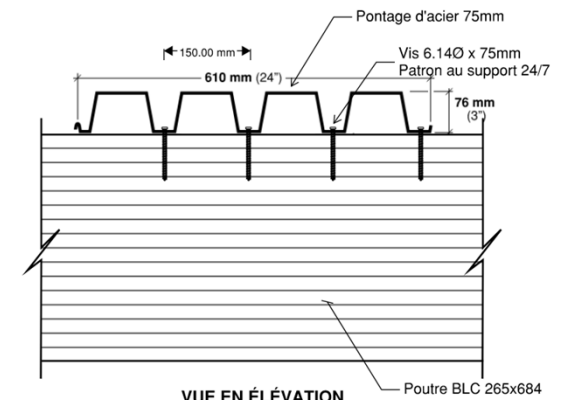

EXEMPLE 1.1

DIAPHRAGME ACIER SUR STRUCTURE DE BOIS

CONSIDÉRATION PRATIQUE

- Type de vis
 - Simpson Strong Tie SDS
 - Vis auto-foreuse bois (Assy, Rothoblass, etc.)
 - Vis autoforeuse avec rondelle d'étanchéité "rubber washer"
- Pré-perçage
 - SDS et Vis auto-foreuse: Référer aux fournisseurs (typ pré-perçage requis)
 - Vis auto-foreuse avec rondelle d'étanchéité :
 - Élément de bois exposés: pré-perçage non requis mais recommandé
 - Si élément de bois couvert: pré-perçage non requis
 - ↑  ↑ \$
- Connection pontage d'acier
 - Rappel qu'en zone sismique élevé (le $F_a S_a(0.2) > 0.45$) et lorsque le diaphragme est dimensionner pour comportement ductile ($R_d R_o = 2$), les assemblages doivent être ductile. Pas de "servissage" = rupture "zipper"



NON-COUVERTS DANS CET EXEMPLE

- Diaphragme de toit → Charge de vent
 - Intéactions cisaillement et tension (soulèvement)
- Déflexion du diaphragme
 - Même equation que propose dans la norme AISI S310-16 mais avec valeur de "slip" pour connexion pontage-bois
 - Simpson Strong Tie publie ces valeurs



EXEMPLE 1.1

DIAPHRAGME ACIER SUR STRUCTURE DE BOIS

RÉFÉRENCES

- Conception de la connexion dans élément de bois → CSA O86
- Conception de la resistance de connexions pontage d'acier a élément de bois → AISI S310-16
- Conception de la connexion et résistance du pontage d'acier → Hilti profis diaphragme
- Information General pontage d'acier → Canam information technique pour tablier métallique en diaphragme

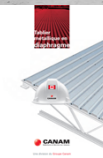

EXEMPLE 1.2

DIAPHRAGME BOIS SUR STRUCTURE D'ACIER

PORTÉE DE L'EXERCICE

- DIAPHRAGME L3
- FORCES SEULEMENT DANS LA DIRECTION N/S
- CONCEPTION DE LA CONNEXION PONTAGE DE BOIS AUX COLLECTEURS D'ACIER
- CONNEXION INTERNE DU DIAPHRAGME DE BOIS
- CALCUL DE DEFLECTION DU DIAPHRAGM

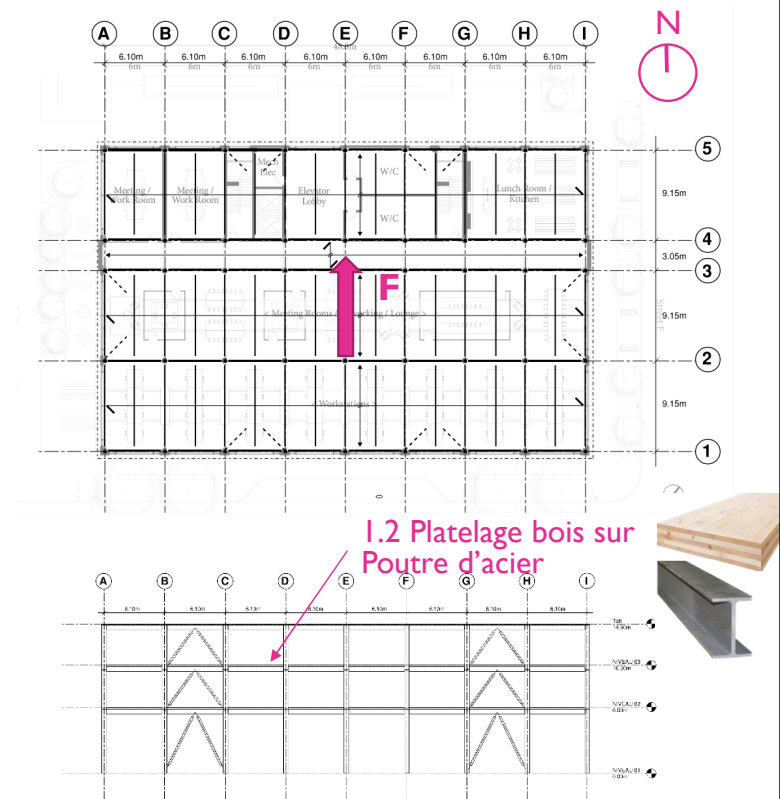

EXEMPLE 1.2

DIAPHRAGME BOIS SUR STRUCTURE D'ACIER

FORCES DE DESIGN DU DIAPHRAGME (L3)

Type de Charge	Combinaison de charge	Ajustement (coefficient de surcapacité γ_i)
Vent		
• $F_W = 142.7 \text{ kN}$	$\times 1.4 = 200.0 \text{ kN}$	$\times 1.0 = 200.0 \text{ kN}$
Seismic		
• $F_{EQ} = 384.2 \text{ kN}$	$\times 1.0 = 384.2 \text{ kN}$	$\times 2.0 = 768.4 \text{ kN}$
• $F_{EQ,min} = 332.1 \text{ kN}$	$\times 1.0 = 332.1 \text{ kN}$	$\times 2.0 = 664.2 \text{ kN}$

**VOIR ANNEXE POUR AJUSTEMENT
DES FORCES SEISMIQUES POUR
CAPACITE DU SFRS**

F (W ou EQ)

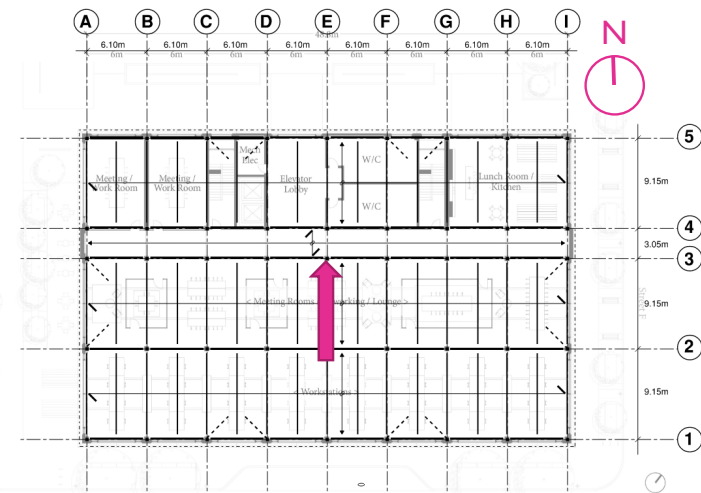
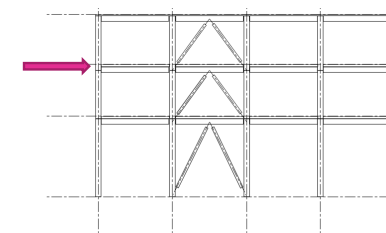

EXEMPLE 1.2

DIAPHRAGME BOIS SUR STRUCTURE D'ACIER

FORCES DE DESIGN DU DIAPHRAGME

Centrée

- $R_A = R_B = 768.4 / 2 = 384.2 \text{ kN}$

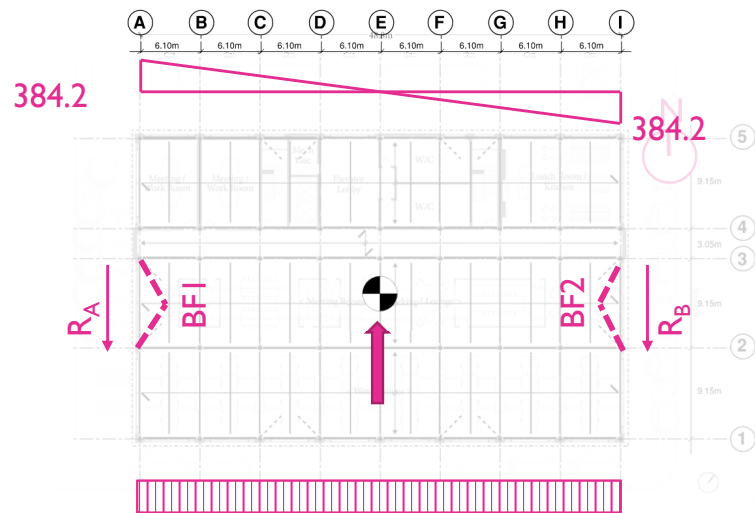

Excentricité accidentelle (10%)

- $R_{A,+10\%} = R_{B,+10\%} = 768.4 \times 0.6 = 461.1 \text{ kN}$
- $R_{A,-10\%} = R_{B,-10\%} = 768.4 \times 0.4 = 307.4 \text{ kN}$

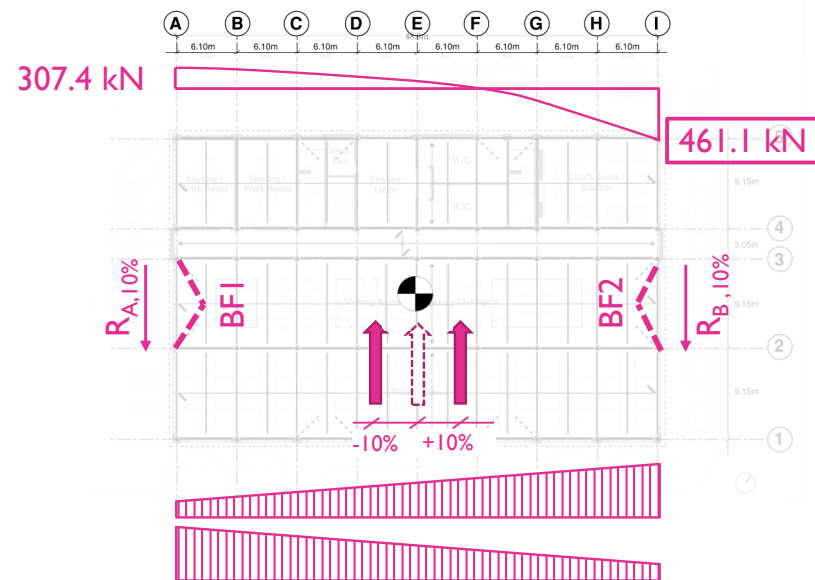

EXEMPLE 1.2

DIAPHRAGME BOIS SUR STRUCTURE D'ACIER

FORCES DE DESIGN DU DIAPHRAGME

Cisaillement longitudinale

- $R_{A,max} = R_{B,max} = 461.1 \text{ kN}$
- $v_F = 461.1 / 30.5 = 15.1 \text{ kN/m}$

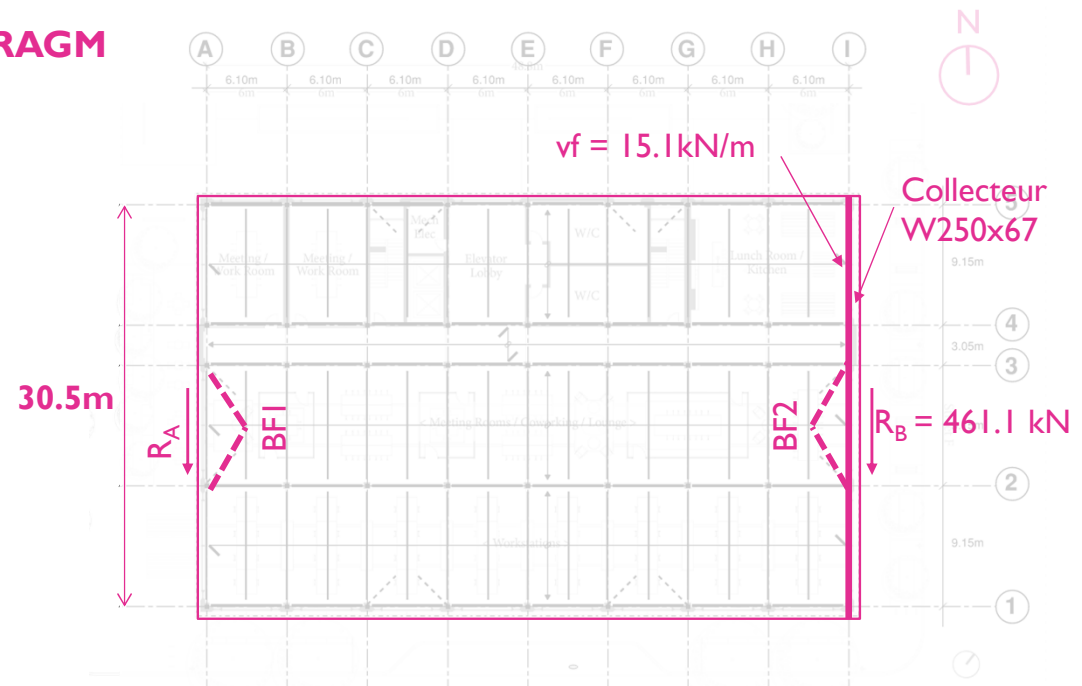

EXEMPLE 1.2

DIAPHRAGME BOIS SUR STRUCTURE D'ACIER

CONCEPTION DE LA CONNECTION PONTAGE DE BOIS AUX COLLECTEURS D'ACIER

- $v_F = 15.1 \text{ kN/m}$
- Connection de type "vis"

$v_F = 15.1 \text{ kN/m}$



VÉRIFICATION

- I. RESISTANCE LATÉRALE A L'ENFONCEMENT – CSA O86-14 Mise-a-jour #1
(Clause 12.6 – Tirefond)

EXEMPLE 1.2

DIAPHRAGME BOIS SUR STRUCTURE D'ACIER

1.0 RESISTANCE LATERALE A L'ENFONCEMENT – CSA O86 (CL. 12.6 TREFOND) MISE-A-JOUR #1

ÉLÉMENT DE LA CONNECTION

Élément #1:

Poutre d'acier W250x67 (350W)
 $f_y = 345 \text{ MPa}$
 $f_u = 450 \text{ MPa}$
 $t_f = 15.7 \text{ mm}$ (épaisseur de l'aile)

Élément #2

Panneau CLT 3pli 105mm (4 1/8")
 V2 (SPF)
 $G = 0.42$
 $t_2 = 56.3 \text{ mm}$ (enfoncement de la vis)
 $\theta = 90^\circ$

Connecteur

Vis auto-foreuses a bois
 Diamètre (d) = 6mm
 Longueur (L) = 80mm
 $F_y = 1000 \text{ MPa}$

FACTEURS ET CONDITIONS DE LA CONNECTION

$K_D = 1.15 \rightarrow$ Courte Durée (EQ)

$K_{SF} = 1.0 \rightarrow$ Bois Sec ($\leq 19\%$) en Milieu Sec

$K_T = 1.0 \rightarrow$ Pas de traitement de préservation ou d'ignifugation

$J_G = 1.0 \rightarrow$ Pas d'effet de groupe

$J_{PL} = 1.0 \rightarrow$ Pénétration $> 8df$

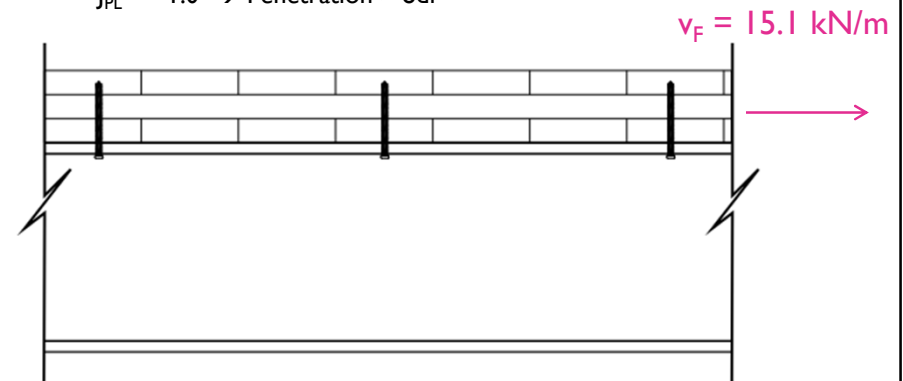

EXEMPLE 1.2

DIAPHRAGME BOIS SUR STRUCTURE D'ACIER

I.0 RESISTANCE LATERALE A L'ENFONCEMENT – CSA O86 (CL. 12.6 TREFOND) MISE-A-JOUR #1

- Resistance Rupture Ductile, Q_r

$$Q_r = \phi_y \cdot Q_u \cdot n_F \cdot J_G \cdot J_{PL}$$

$$\phi_y = 0.6$$

$$n_F = 1$$

$$J_G = 1$$

$$J_{PL} = 1$$

Calcul de Q_u

$$Q_u = q_u \cdot (K_D \cdot K_{SF} \cdot K_T)$$

$$K_D = 1.15$$

$$K_{SF} = 1$$

$$K_T = 1$$

$$q_u = \text{voir prochaine page}$$

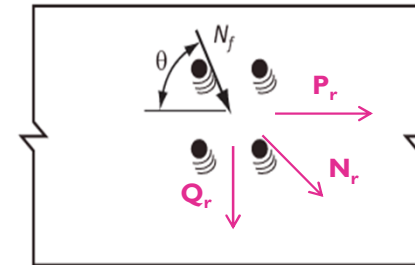

Yielding

12.6.6 Lateral resistance

12.6.6.1 Side grain

Δ 12.6.6.1.1

The factored lateral strength resistance of a lag screw connection, P_r , Q_r , or N_r , shall be greater than or equal to the effect of the factored loads, as follows:

- (a) for parallel-to-grain loading:

$$P_r = \phi P_u \phi_c J_G J_{PL}$$

- (b) for perpendicular-to-grain loading:

$$Q_r = \phi Q_u n_F J_G J_{PL}$$

- (c) for loads at angle θ to grain:

$$N_r = \frac{P_r Q_r}{P_r \sin^2 \theta + Q_r \cos^2 \theta}$$

EXEMPLE 1.2

DIAPHRAGME BOIS SUR STRUCTURE D'ACIER

I.0 RESISTANCE LATÉRALE A L'ENFONCEMENT – CSA O86 (CL. 12.6 TIREFOND) MISE-A-JOUR #1

- Resistance Rupture Ductile, Q_r (suite)

Calcul de q_u

$$d_F = 6 \text{ mm}$$

$$t_1 = 15.7 \text{ mm}$$

$$t_2 = 80 - 15.7 - 8 = 56.3 \text{ mm}$$

$$f_1 = K_{sp} \cdot (\phi_{steel} / \phi_{wood}) \cdot f_u$$

$$f_1 = 3.0 \cdot (0.8 / 0.6) \cdot 450$$

$$f_1 = 1800 \text{ MPa}$$

$$f_2 = 22 \cdot G \cdot (1 - 0.01 \cdot d_F)$$

$$f_2 = 22 \cdot 0.42 \cdot (1 - 0.01 \cdot 8)$$

$$f_2 = 8.5 \text{ MPa}$$

$$f_y = 1000 \text{ MPa}$$

For steel side plates:

$$f_1 = K_{sp} (\phi_{steel} / \phi_{wood}) f_u$$

where

$$K_{sp} = 3.0 \text{ for mild steel referenced in CSA S16}$$

$$= 2.25 \text{ for cold-formed light gauge steel referenced in CSA S136}$$

f_u = specified minimum tensile strength of steel

Note: The specified minimum tensile strength of steel, f_u , is given in the relevant material standards, e.g., for

(a) ASTM A36/A36M steel, $f_u = 400 \text{ MPa}$;

(b) CSA G40.21 steel, Grades 300W and 350W, $f_u = 450 \text{ MPa}$; and

(c) cold-formed light gauge steel, Grade SS 230, $f_u = 310 \text{ MPa}$.

ϕ_{steel} = resistance factor for steel plates in connections with lag screws

$$= 0.8 \text{ for mild steel referenced in CSA S16}$$

$$= 0.5 \text{ for cold-formed light gauge steel referenced in CSA S136}$$

ϕ_{wood} = resistance factor for wood members in connections with lag screws

$$= 0.6$$

f_2 = embedment strength of main member, MPa

$$= 50G (1 - 0.01 d_F) J_x \text{ for parallel-to-grain loading}$$

$$= 22G (1 - 0.01 d_F) \text{ for perpendicular-to-grain loading}$$

where

G = mean relative density (Table A.12.1)

J_x = 0.90 for CLT

= 1.0 in all other cases

EXEMPLE 1.2

DIAPHRAGME BOIS SUR STRUCTURE D'ACIER

1.0 RESISTANCE LATERALE A L'ENFONCEMENT MISE-A-JOUR #1

- Resistance Rupture Ductile, Q_r (suite)

Calcul de q_u

$$d_F = 6 \text{ mm}$$

$$t_1 = 15.7 \text{ mm}$$

$$t_2 = 75 - 15.7 - 8 = 56.3 \text{ mm}$$

$$f_1 = K_{sp} \cdot (\Phi_{steel} / \Phi_{wood}) \cdot f_u$$

$$f_1 = 3.0 \cdot (0.8 / 0.6) \cdot 450$$

$$f_1 = 1800 \text{ MPa}$$

$$f_2 = 22 \cdot G \cdot (1 - 0.01 \cdot d_F)$$

$$f_2 = 22 \cdot 0.42 \cdot (1 - 0.01 \cdot 6)$$

$$f_2 = 8.7 \text{ MPa}$$

$$f_y = 1000 \text{ MPa}$$

11.9.2.2 Energy dissipative connections

Energy dissipative connections of CLT structures shall satisfy all of the following requirements:

- connections shall be designed so that a yielding mode governs the resistance;
- connections shall be at least moderately ductile in the directions of the assumed rigid body motions of CLT panels; and
- connections shall possess sufficient deformation capacity to allow for the CLT panels to develop their assumed deformation behaviour, such as rocking, sliding, or combination thereof.

Note: For further information on moderately ductile connections, see the CWC Commentary on CSA O86.

(a) $f_1 d_f t_1$



$$q_u \text{ (a)} = 169.6 \text{ kN}$$

(b) $f_2 d_f t_2$



$$q_u \text{ (b)} = 2.9 \text{ kN}$$

(c) $f_1 d_f^2 \sqrt{\frac{1}{6} \frac{f_2}{(f_1 + f_2)} \frac{f_y}{f_1} + \frac{1}{5} \frac{t_1}{d_f}}$



$$q_u \text{ (c)} = 35.3 \text{ kN}$$

(d) $f_1 d_f^2 \sqrt{\frac{1}{6} \frac{f_2}{(f_1 + f_2)} \frac{f_y}{f_1} + \frac{1}{5} \frac{t_2}{d_f}}$



$$q_u \text{ (d)} = 123.0 \text{ kN}$$

(e) $f_1 d_f^2 \frac{1}{5} \left(\frac{t_1}{d_f} + \frac{f_2}{f_1} \frac{t_2}{d_f} \right)$



$$q_u \text{ (e)} = 34.5 \text{ kN}$$

(f) $f_1 d_f^2 \sqrt{\frac{2}{3} \frac{f_2}{(f_1 + f_2)} \frac{f_y}{f_1}}$



$$q_u \text{ (f)} = 2.7 \text{ kN} \quad \text{OK!}$$

EXEMPLE 1.2

DIAPHRAGME BOIS SUR STRUCTURE D'ACIER

I.0 RESISTANCE LATERALE A L'ENFONCEMENT – CSA O86 (CL. 12.1 I VISA BOIS)

- Resistance Rupture Ductile, Q_r

Calcul de Q_u (suite)

$$Q_u = q_u \cdot (K_D \cdot K_{SF} \cdot K_T)$$

$$Q_u = 2.7 \cdot (1.15 \cdot 1 \cdot 1)$$

$$Q_u = 3.1 \text{ kN}$$

$$q_u = 2.7$$

$$K_D = 1.15$$

$$K_{SF} = 1$$

$$K_T = 1$$

$$Q_r = \phi_y \cdot Q_u \cdot n_F \cdot J_G \cdot J_{PL}$$

$$Q_r = 0.6 \cdot 3.1 \cdot 1 \cdot 1 \cdot 1$$

$$Q_r = 1.86 \text{ kN}$$

- Nombre de Connecteurs requis par mètre linéaire

$$v_F = 15.1 \text{ kN/m}$$

$$n \geq v_F / Q_r$$

$$n \geq 15.1 / 1.86$$

$$n \geq \mathbf{8.1 \text{ vis / m}}$$

EXEMPLE 1.2

DIAPHRAGME BOIS SUR STRUCTURE D'ACIER

SOMMAIRE - CONCEPTION DE LA CONNEXION

1.0 RESISTANCE LATÉRALE A L'ENFONCEMENT – CSA O86 (CL. 12.6 TIF)

- 8.1 vis requises/m \rightarrow Nb vis = $2 \times 1000/200 = 10$ vis/m **OK!**

Espacement requis selon CSA O86

- Minimum Row spacing = $5d = 5 \times 6 = 30\text{mm} \rightarrow 100\text{mm}$
- Min spacing in a row = $3d = 3 \times 6 = 18\text{mm} \rightarrow 200\text{mm}$
- Min edge distance = $3 \times d = 3 \times 6 = 18\text{mm} \rightarrow 50\text{mm}$

OK!

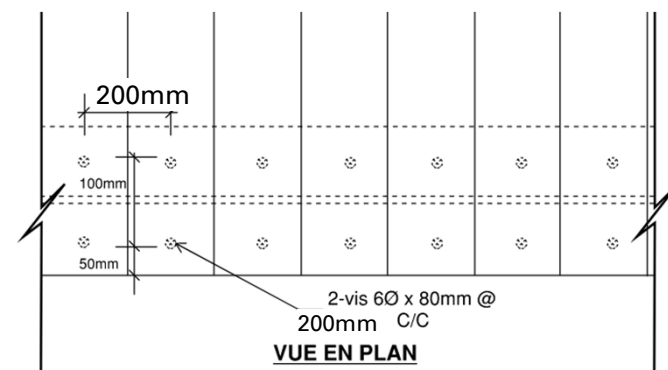
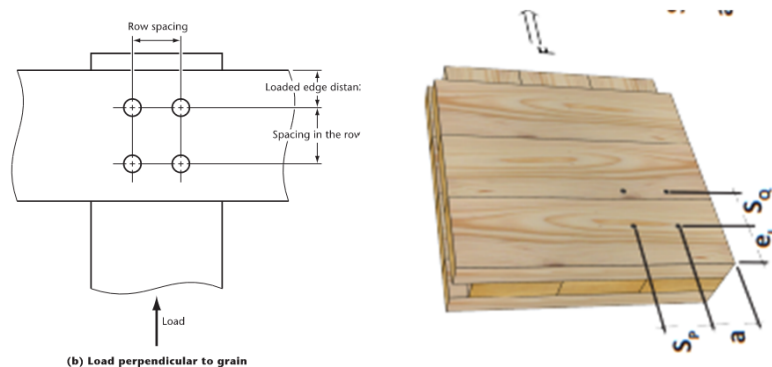
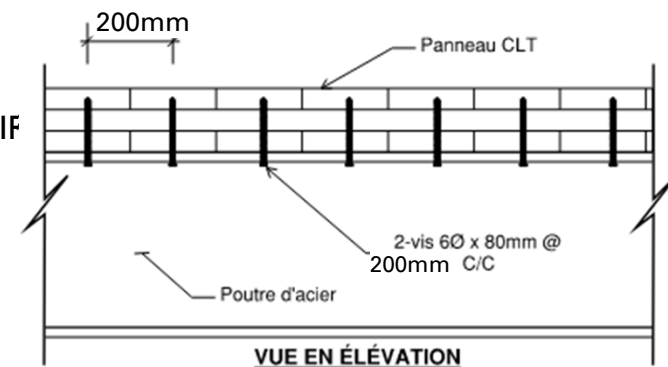

EXEMPLE 1.2

DIAPHRAGME BOIS SUR STRUCTURE D'ACIER

SOMMAIRE - CONCEPTION DE LA CONNEXION

Détail alternatif

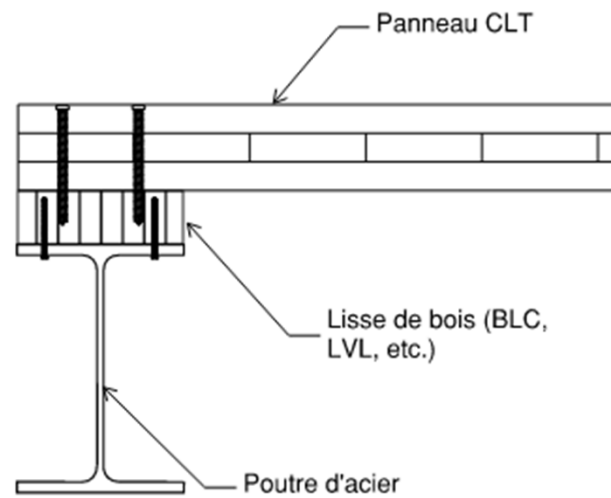

EXEMPLE 1.2

DIAPHRAGME BOIS SUR STRUCTURE D'ACIER

CONCEPTION DE LA CONNEXION INTERNE DU DIAPHRAGME DE BOIS

- Différentes options possibles

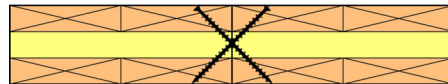
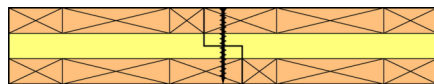
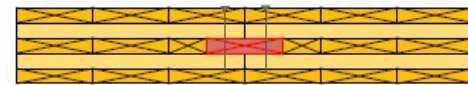
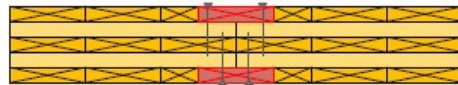
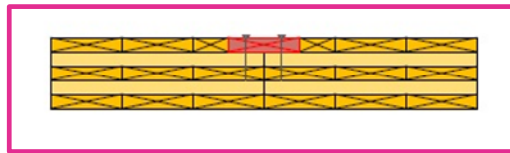

EXEMPLE 1.2

DIAPHRAGME BOIS SUR STRUCTURE D'ACIER

CONCEPTION DE LA CONNEXION INTERNE DU DIAPHRAGME

- $v_F = 15.1 \text{ kN/m}$
- Connection de type "vis"

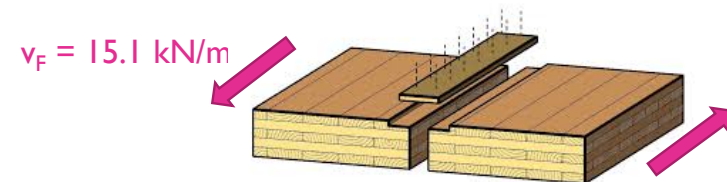

VÉRIFICATION

I. RESISTANCE LATÉRALE A L'ENFONCEMENT –

I.1 CSA O86-14 Mise-a-jour #1 (Clause 12.6 – Tirefond)

I.2 Simpson Strong Tie – Table de résistance au cisaillement

EXEMPLE 1.2

DIAPHRAGME BOIS SUR STRUCTURE D'ACIER

CONCEPTION DE LA CONNEXION INTERNE DU DIAPHRAGME

- Table de résistance en cisaillement Simpson Strong Tie

Factored Shear Resistance

Model No.	Ga.	CLT Layup	Fasteners	Fastener Spacing (in.)	Factored Lateral Resistance ($K_D = 1.15$)				Slip Modulus			
					lb./ft.		kN/m		lb./in.		kN/mm	
					DF/SP	SPF/HF	DF/SP	SPF/HF	DF/SP	SPF/HF	DF/SP	SPF/HF
MDSS96	14	Three-Ply	¼" x 3½" SDS	8	1010	905	14.74	13.21	16875	16875	2.96	2.96
				6	1345	1210	19.63	17.66	16875	16875	2.96	2.96
				4	2020	1810	29.48	26.41	16875	16875	2.96	2.96
		Five-Ply, Seven-Ply	¼" x 6" SDS	8	1010	905	14.74	13.21	16875	16875	2.96	2.96
				6	1345	1210	19.63	17.66	16875	16875	2.96	2.96
				4	2020	1810	29.48	26.41	16875	16875	2.96	2.96
CMSTC16	16	Three-Ply	0.148" x 2½"	3	1105	985	16.13	14.37	7685	7685	1.35	1.35
				1½	2210	1970	32.25	28.75	7685	7685	1.35	1.35
				8	595	595	8.68	8.68	6700	6700	1.17	1.17
SDWS Screws w/ 1½" Plywood	N/A	Three-Ply	0.22" x 4" SDWS	8	795	795	11.60	11.60	6700	6700	1.17	1.17
				6	1195	1195	17.44	17.44	6700	6700	1.17	1.17
				4	1195	1195	17.44	17.44	6700	6700	1.17	1.17
		Five-Ply, Seven-Ply	0.22" x 6" SDWS	8	615	615	8.98	8.98	6700	6700	1.17	1.17
				6	820	820	11.97	11.97	6700	6700	1.17	1.17
				4	1230	1230	17.95	17.95	6700	6700	1.17	1.17

$$v_f = 15.1 \text{ kN/m}$$

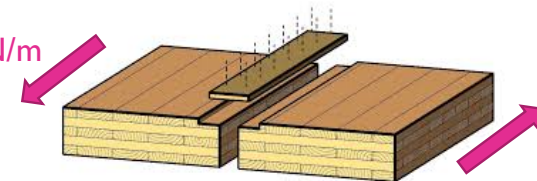

Connexion réalisée avec une "plaque" de jonction en plywood 28mm (1 1/8"), connectée avec vis SDS 5.6x100 @ 100mm (4") C/C

$$v_r \geq v_f$$

$$17.44 \geq 15.1 \quad \text{OK!}$$

on ne connaît pas le mode rupture ductile

EXEMPLE 1.2

DIAPHRAGME BOIS SUR STRUCTURE D'ACIER

CALCUL DÉFLEXION DU DIAPHRAGME

$$\delta_{dia} = \frac{5vL^3}{8EAW} + \frac{vL}{4G_v t_v} + CLe_n + \frac{\Sigma(x\Delta_c)}{2W}$$

FLEXION
CISAILLEMENT
"SLIP" CONNEXION
"SLIP" CORDE T&C

- Déflexion due a la flexion

$$\delta = 5vL^3/8EAW$$

$$\delta = 5 \cdot 24.6 \cdot (48,000^3)/8 \cdot 200,000 \cdot 8550 \cdot 30,500$$

$$\delta = 34.3\text{mm}$$

- Déflexion due au cisaillement

$$\delta = vL/4G_v t_v$$

$$\delta = wL^2/8AG_{eff,CLT}$$

$$\delta = 30.7 \cdot 48,000^2/8 \cdot (105 \cdot 30,500) \cdot 206.8$$

$$\delta = 13.8\text{mm}$$

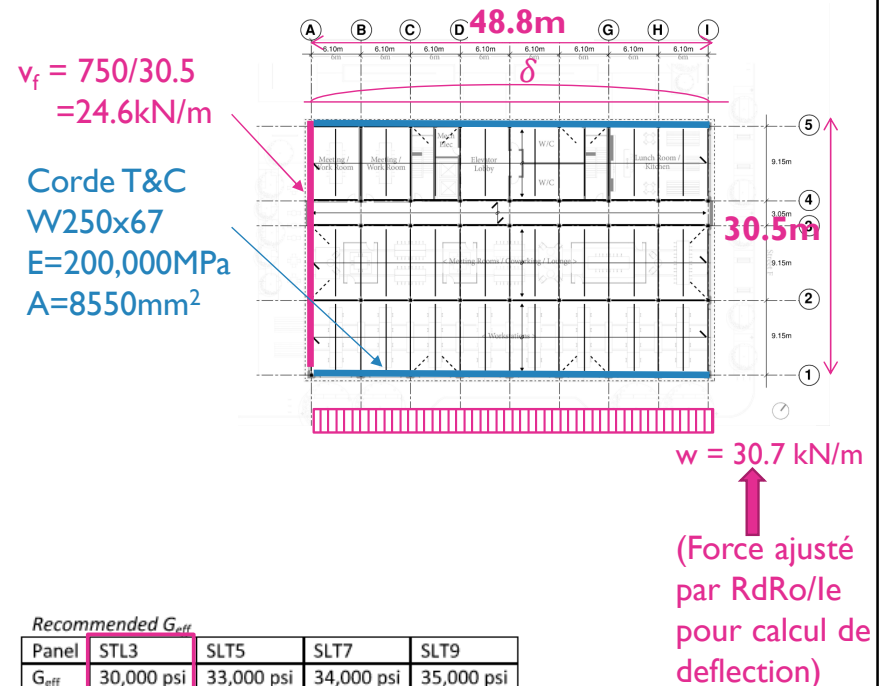

EXEMPLE 1.2 DIAPHRAGME BOIS SUR STRUCTURE D'ACIER

CALCUL DÉFLEXION DU DIAPHRAGME

- Déflexion due au "slip" des assemblages inter-panneaux

$$\delta = CLe_n$$

$$\delta = 0.000205 \cdot 48800 \cdot 1.49$$

$$\delta = 14.9\text{mm}$$

$$C = (1/P_L + 1/P_w) / 2 = 0.000205$$

$$P_L = 12200\text{mm} (40')$$

$$P_w = 3050\text{mm} (10')$$

$$L = 48,800\text{mm} (160')$$

$$e_n = (17.44 \cdot 100/1000)/1.17 = 1.49$$

$\delta_y = CLe_n$
 where,
 $C = (1/P_L + 1/P_w) / 2$
 $P_L =$ Length of individual CLT panel (ft.)
 $P_w =$ Width of individual CLT panel (ft.)
 $L =$ Overall length of diaphragm (ft.)
 $e_n =$ Force per fastener [lb.]/Slip modulus [lb./in.]

- Déflexion due au "slip" des cordes (T&C)

$$\delta = \cancel{vL/4G_v t_v} \rightarrow 0$$

$$\delta = 0\text{mm}$$

- Déflexion totale du diaphragme

$$\delta_{total} = 34.3 + 13.8 + 14.9 + 0$$

$$\delta_{total} = 63.0\text{mm}$$

Factored Shear Resistance

Model No.	Ga.	CLT Layup	Fasteners	Fastener Spacing (in.)	Factored Lateral Resistance ($K_n = 1.15$)				Slip Modulus			
					lb./ft.		kN/m		lb./in.		kN/mm	
					DF/SP	SPF/HF	DF/SP	SPF/HF	DF/SP	SPF/HF	DF/SP	SPF/HF
MDSS96	14	Three-Ply	¼" x 3½" SDS	8	1010	905	14.74	13.21	16875	16875	2.96	2.96
				6	1345	1210	19.63	17.66	16875	16875	2.96	2.96
				4	2020	1810	29.48	26.41	16875	16875	2.96	2.96
		Five-Ply, Seven-Ply	¼" x 6" SDS	8	1010	905	14.74	13.21	16875	16875	2.96	2.96
				6	1345	1210	19.63	17.66	16875	16875	2.96	2.96
				4	2020	1810	29.48	26.41	16875	16875	2.96	2.96
CMSTC16	16	Three-Ply	0.148" x 2½"	3	1105	985	16.13	14.37	7685	7685	1.35	1.35
				1½	2210	1970	32.25	28.75	7685	7685	1.35	1.35
				8	595	595	8.68	8.68	6700	6700	1.17	1.17
				6	795	795	11.60	11.60	6700	6700	1.17	1.17
				4	1195	1195	17.44	17.44	6700	6700	1.17	1.17
				8	615	615	8.98	8.98	6700	6700	1.17	1.17
SDWS Screws w/ 1¼" Plywood	N/A	Three-Ply	0.22" x 4" SDWS	8	820	820	11.97	11.97	6700	6700	1.17	1.17
				6	820	820	11.97	11.97	6700	6700	1.17	1.17
				4	1230	1230	17.95	17.95	6700	6700	1.17	1.17
		Five-Ply, Seven-Ply	0.22" x 6" SDWS	8	615	615	8.98	8.98	6700	6700	1.17	1.17
				6	820	820	11.97	11.97	6700	6700	1.17	1.17
				4	1230	1230	17.95	17.95	6700	6700	1.17	1.17

EXEMPLE 1.2

DIAPHRAGME BOIS SUR STRUCTURE D'ACIER

CONSIDERATION PRATIQUE

- Type de vis
 - Simpson Strong Tie SDS
 - Vis auto-foreuse bois (Assy, Rothoblass, Heco, Würth, etc.)
- Type de tête pour connexion avec plaque d'acier
 - Hex head
 - Countersunk head: Requiert machinage (fraisage)
- Analyse du diaphragme complexe (ouverture & "offset")
 - Analyse avec diaphragme de type "Rigide"
 - Analyse avec diaphragme de type "Semi-Rigide"
 - *** Rigidité du CLT en plan → modificateur de rigidité
 - Enveloppe (Rigid + Semi-Rigide)

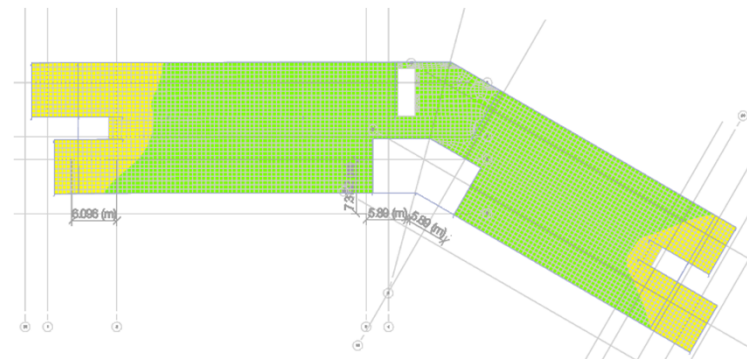

EXEMPLE 1.2

DIAPHRAGME ACIER SUR STRUCTURE DE BOIS

RÉFÉRENCES

- Conception de la connexion bois/acier et bois/bois
- Conception de la deflection du diaphragme de bois
- MTC table d'espacement et de resistance
- Simpson Strong tie: Table de resistance et valeurs de "slip"

→ CSA O86-14 Mise a jour #1



→ Guide d'utilisation technique "CLT Horizontal Diaphragm Design Example" de Structurlam et MTC



BOIS BÉTON COMPOSITE



BOIS BÉTON COMPOSITE

APPLICATIONS

POUTRES BBC

- BLC
- LVL
- BOIS MASSIF ...

PANNEAUX BBC

- CLT
- MPP
- BLC
- LVL
- NLT/DLT







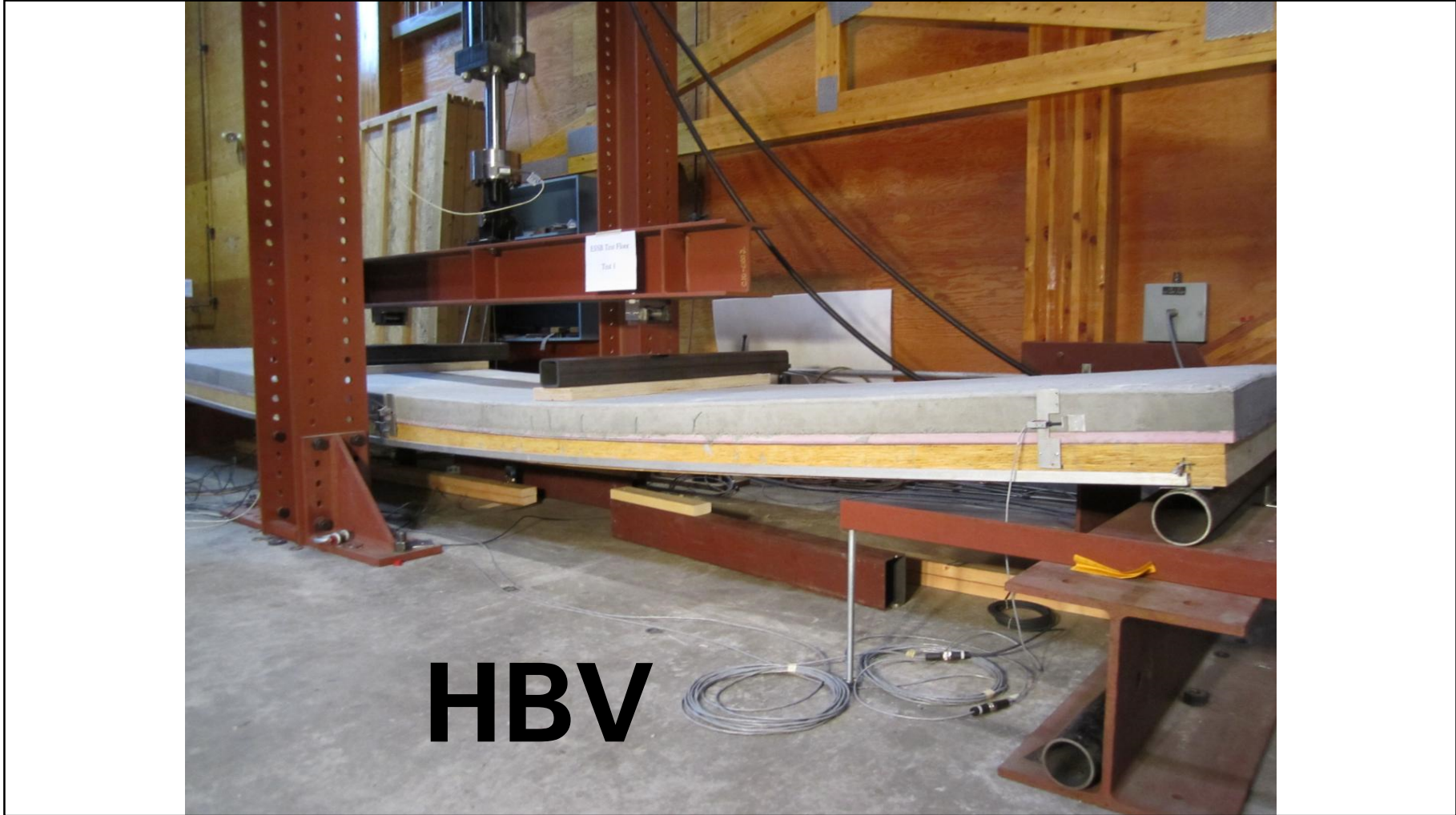

VIS AUTOFOREUSE



ENCOUCHE



PLAQUE D'ENTAILLE



600,000 sq. ft. aire totale
250,000 sq. ft. en BBC

PLAQUE D'ENTAILLE

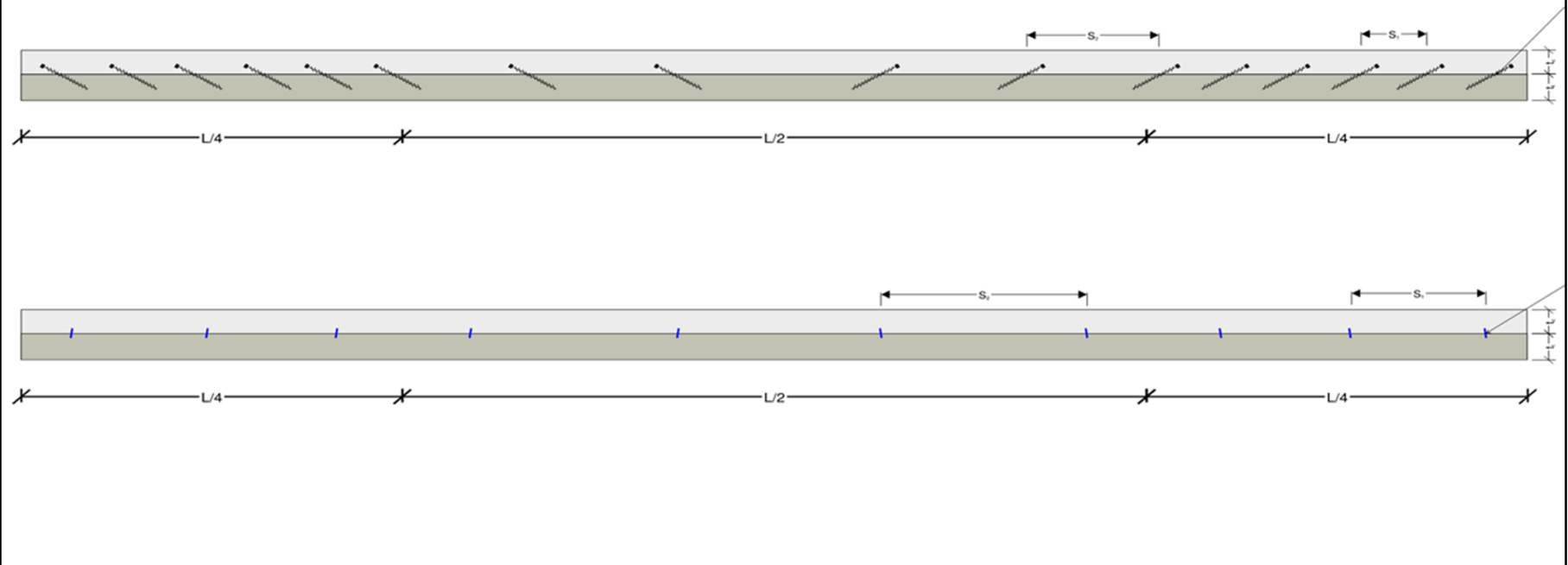



BOIS BÉTON COMPOSITE

QUAND UTILISER BBC

- Grande portée
- Conserver épaisseur de plancher mince
- Contrôle de la déflexion
- Contrôle de la vibration
- ↑ \$\$\$

MÉTHODE DE CALCUL

- Gama etc.

RÉFÉRENCES

- Guide FPIinnovations
- Guide technique BBC avec vis par MTC
- Fiche technique Nationale (Allemagne)
- Articles & Recherches Canadiennes

CONNECTEURS INNOVANTS





TIGES FILLETÉES



ÉTRIER PRÉ-CONÇU

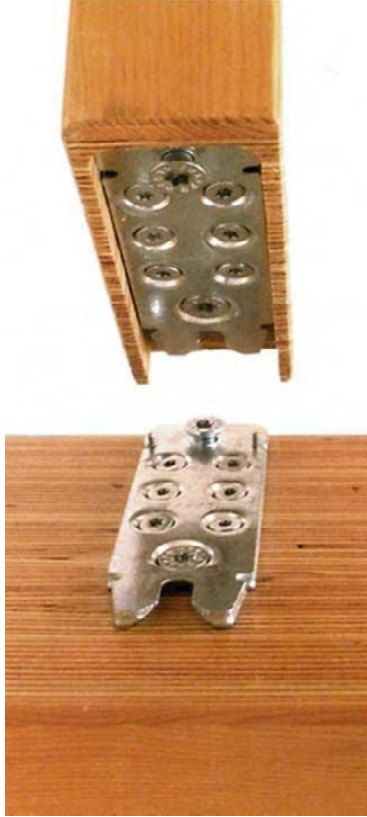
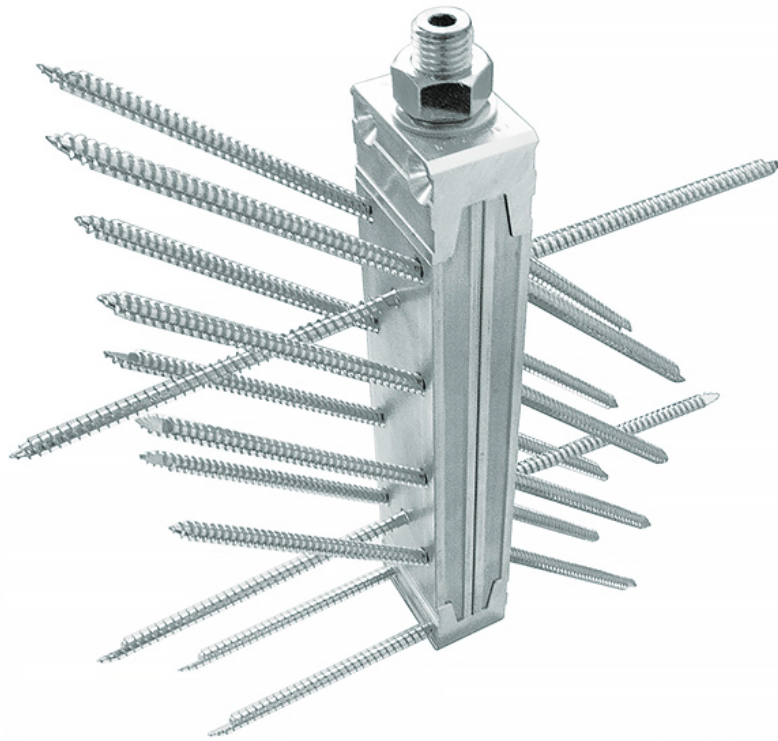

n'H GSA TECHNOLOGY

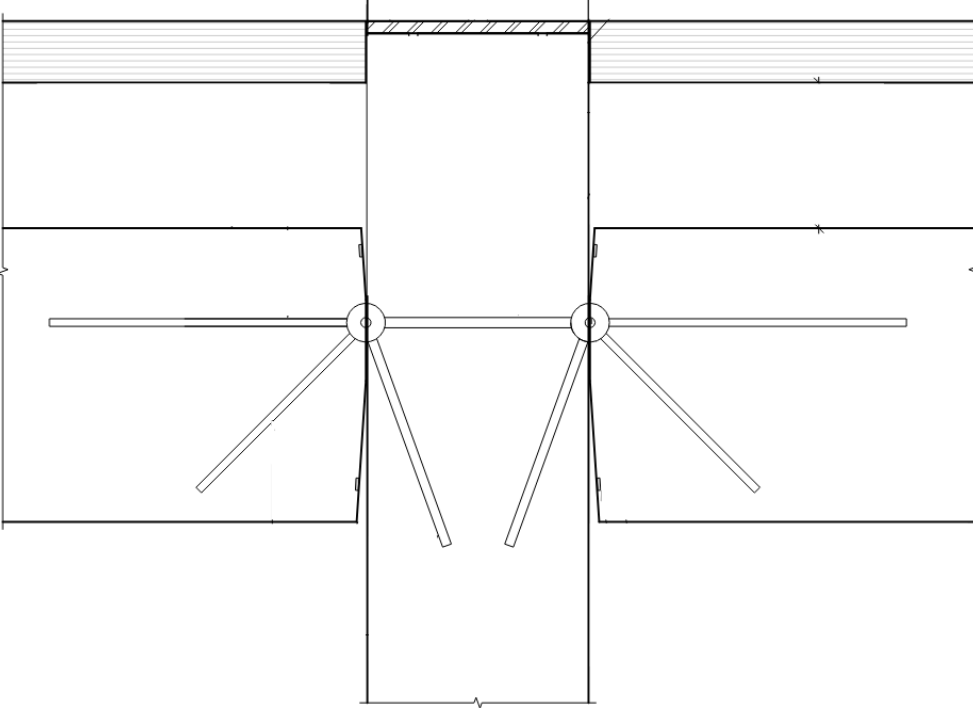

TS3

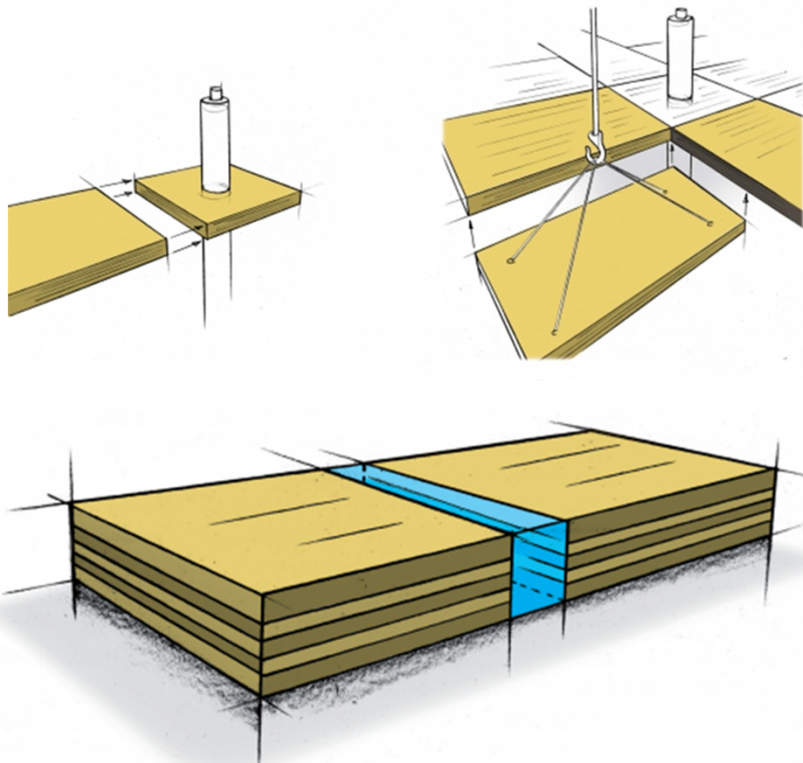

TS3
Timber Structures 3.0

TECTONUS



TECTONUS



SPIDER

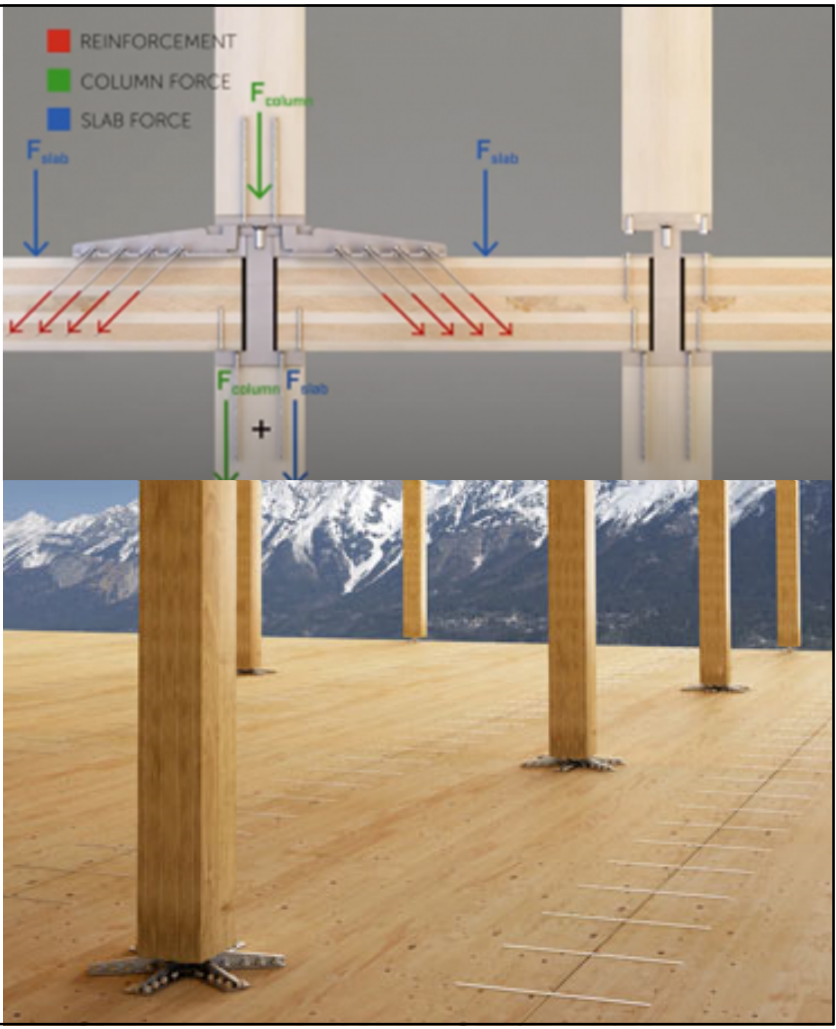
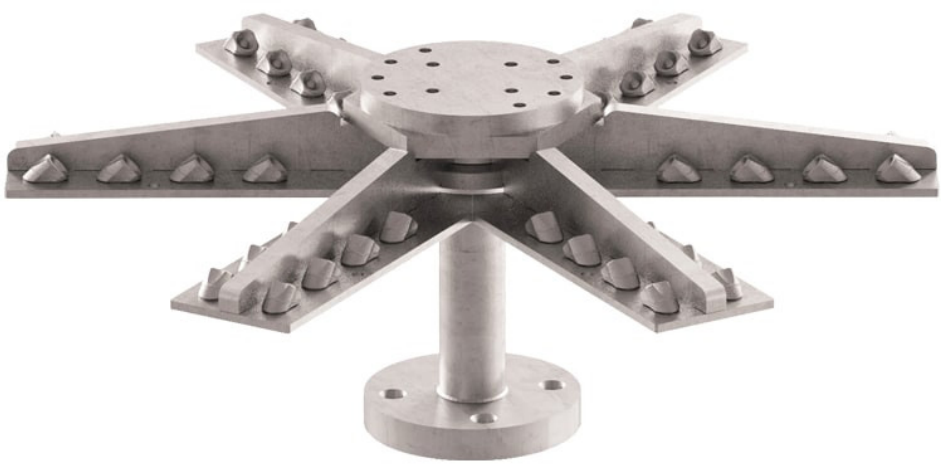

MERCI!

ASPECT
STRUCTURAL ENGINEERS